

EST.  1907

FRIESENS

MEMORIES CRAFTED IN PRINT

— EMPLOYEE-OWNED —

COVERS GUIDE

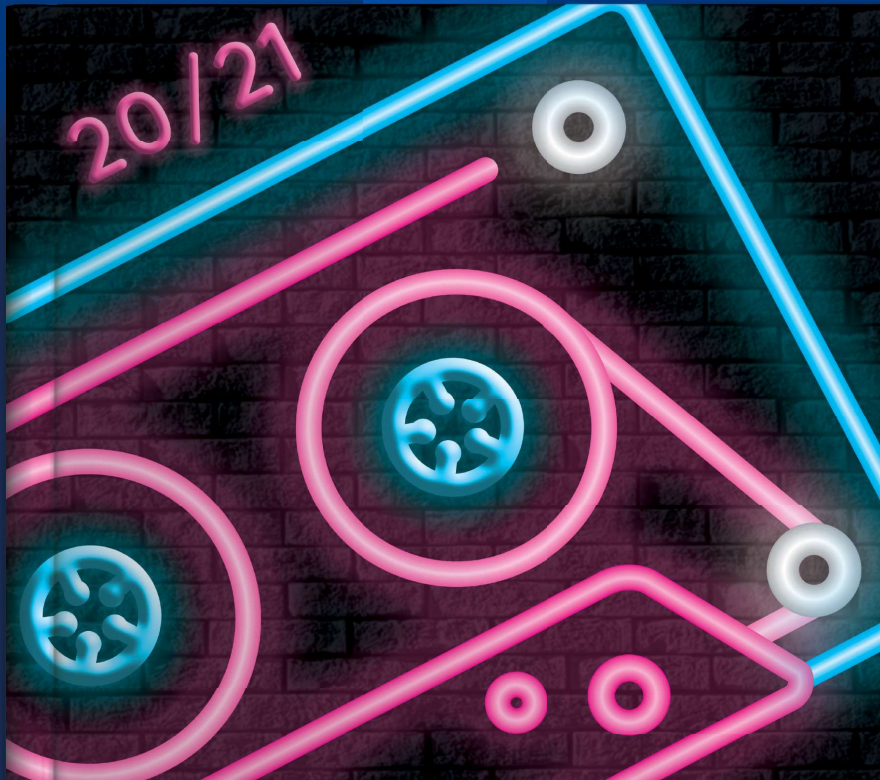

PREPARING ARTWORK

ARTWORK CAN BE SUPPLIED IN A FEW WAYS.

CUSTOM COVER

An original drawing or painting can be mailed to us, which we would then scan with our high quality scanner, create a digital file and add any text or design elements you would like on the cover.

Supply digital images that we will place on a cover template in the arrangement as per your instructions and add any text you would like on the cover.

Supply Friesens with your digital file, created in one of our supported programs. We will then make any adjustments necessary to fit the cover/spine size for your yearbook.

STOCK COVER

If choosing a stock cover design, just email your Service Specialist the stock cover name and the text you would like on the cover. A school crest or logo may also be added.

PROGRAMS SUPPORTED BY FRIESENS FOR SUPPLYING DIGITAL COVER FILES:

- Adobe Photoshop 3.0 and higher
- Adobe Illustrator 4.0 and higher
- Adobe InDesign 1.5 and higher
- CorelDRAW 7.0 and higher

PLACEMENT OF PERSONALIZING

Personalizing is normally placed in the bottom right hand corner of the cover. Other placements may be possible but must be confirmed by your Customer Service Specialist prior to submission.

POINTS TO REMEMBER

- Choose ink colours from an ink colour swatch, not from your monitor. Monitors tend to display false colours.
- Always submit all fonts and images you have used to create your cover.
- All digital image files need to be saved as TIFF, JPG, EPS or PSD format, with a resolution of 300 DPI (dots per inch) at actual size.
- Full colour covers need to be saved in CMYK format.
- If supplying Photoshop files, please leave in layers so minor adjustments can be made by Friesens to make sure your artwork will fit the cover template.
- For areas that are to have spot UV coating or embossing, you can create a separate layer indicating so, or supply us with instructions as to which elements should have the effect applied.
- Using clear, precise instructions will eliminate the chance of your cover artwork being produced in the wrong way.
- Note that the cover size for any hard cover book is not the same size as the inside pages. The cover extends past the pages and includes a hinge area on either side of the spine. InDesign cover templates can be found on ConnectMe, or you can request one from your Customer Service Specialist. We can also supply you with Photoshop templates to help you create artwork at the perfect size.
- Endsheets are the same size as a double page spread in your yearbook.

COVER PROOFING

After you have submitted your cover and endsheet files to the team at the plant, our prepress team reviews the files, and prepares them for a final proof. The Prepress team will do their best to ensure that your spine is the correct size, and will complete any additional design requests at this time. From there, you will receive a proof, which may come as either an email or a physical package mailed to you.

This proof will come with confirmation on your order quantity, as well the cover material and treatments. When you receive your cover or endsheet proof files, there are several things to review and consider before returning it to your Customer Project Specialist:

- Is the spelling correct?
- Is the spine text aligned properly?
- Are all dates or years noted correctly?
- Do you have any special applications to your cover (embossing, spot gloss, foil)? If so, are they represented correctly on the files?

SAMPLE COVER TEMPLATE

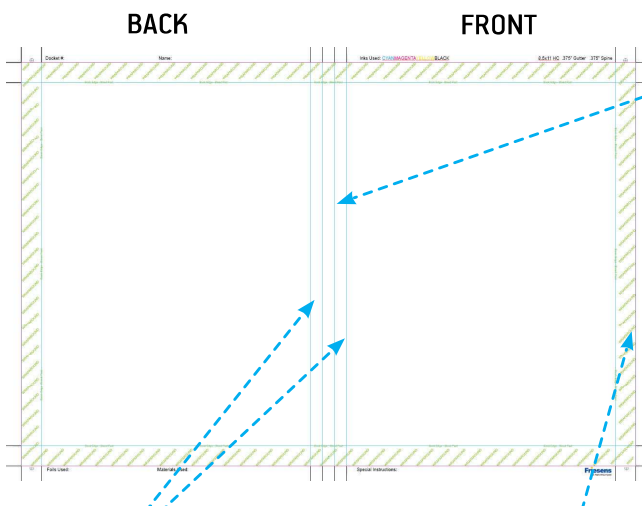

SPINE:

This is the area that will show when your book is on a bookshelf. Usually your school name and year can be placed here, as well as the book title if you wish. For an English book, the spine text should start at the top and read towards the bottom. Spine text runs the opposite way for a French book.

HINGE/GUTTER AREA:

This is the area between the cover board and the spine. It gets “smashed” in during binding. Type and important elements should not be placed in the hinge area.

WRAPAROUND AREA:

This area will be wrapped around the cover board to the inside and the endsheet will be glued over top. Anything that you would like to appear on the cover should not be in this area. Any images or background colours that are to bleed off the cover should fill this area.

The following pages show samples of cover options available to you. The samples are actual covers designed by schools and are not available as stock designs.

COVER OPTIONS

PROCESS COLOUR

One or more ink colours are applied to paper for limitless design potential. Any artwork, photographs or digital designs can be printed with this process. For durability and protection, a plastic lamination is applied with either a gloss or matte finish.

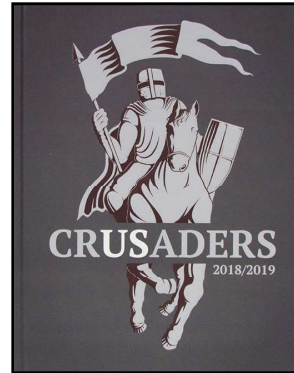
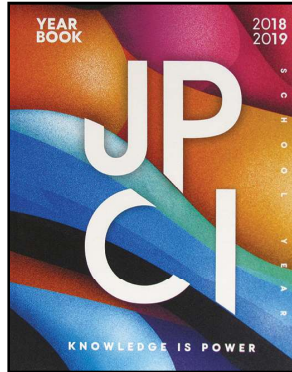

QUARTER BINDING

For a classic traditional look, no other application brings it all together like quarter binding. Quarter binding utilizes two colours of material – either two different types of material, or is “faked” by using a different colour of ink on the same material.

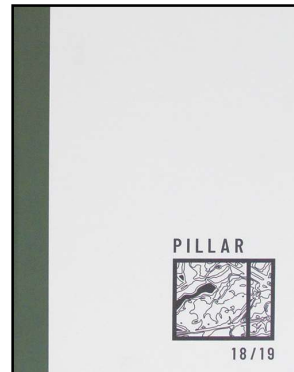
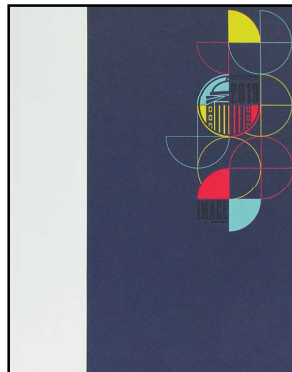
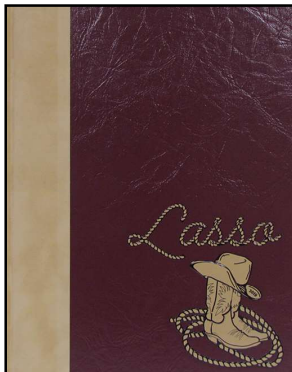

EMBOSSING

An embossed cover uses a brass die to press a design into the cover to raise specific areas. Debossing uses a similar die to indent specific areas. You can create your own design or use one of our pre-made stock designs. When embossing, you have the option of requesting a grain at no charge. (see page 8 for grain samples)

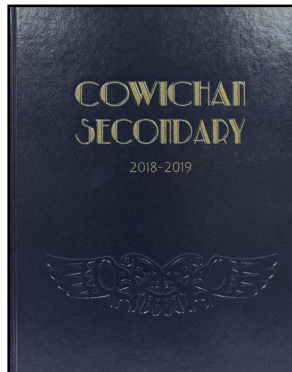
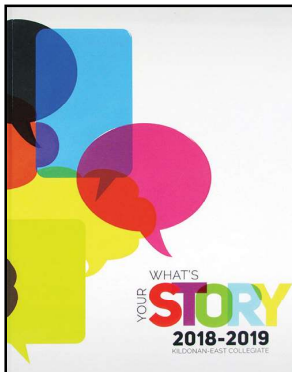

COVER OPTIONS

FOIL STAMPING

Add style to your cover by presenting your cover artwork in foil rather than ink. Foil stamping adds a dynamic flair to your cover and can highlight important elements of your design.

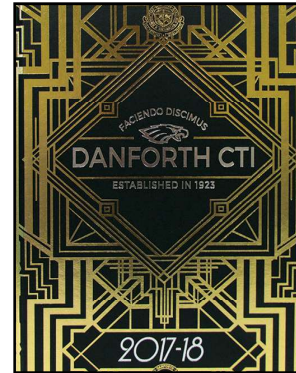
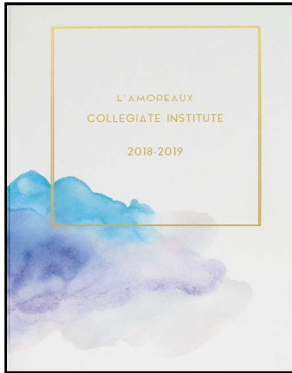

3D METAL INLAY

A metal inlay is an application that combines a layer of metal with sculptured embossing for a very special effect. Metal inlays are available in six colours including: gold, silver, copper, blue, green and red.

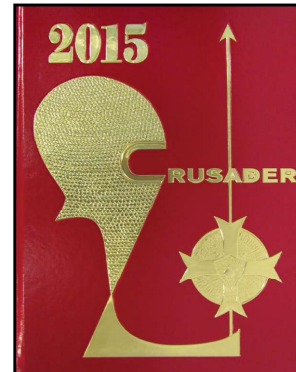
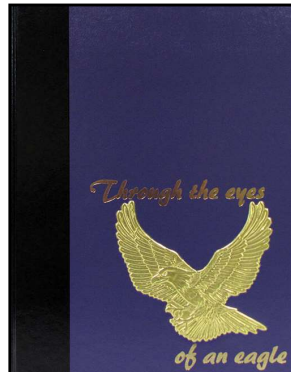

DIE CUTTING

Growing in popularity, die cutting is the process of cutting a pre-designed shape directly through the cover. When the yearbook is closed, the endsheet can be seen through the die-cut opening in the cover. Note that diecut shapes should be kept fairly simple and may need to be modified in order to produce the best product.

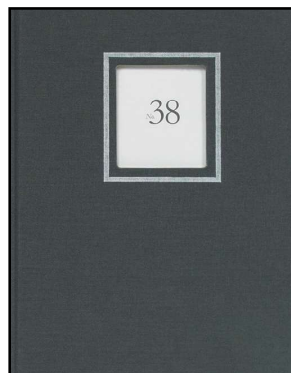
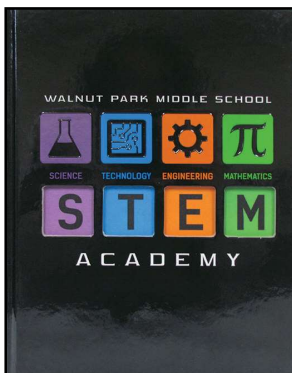

CRYSTALLINE

Crystalline covers are printed on white paper using an offset or digital press, and then laminated for durability and protection. They have a nearly limitless design potential and can have several other applications applied to them.

- Choose from gloss or matte
- Apply a spot UV coating to highlight design elements in a glossy finish
- Apply a linen weave embossing for a canvas like texture
- Emboss or deboss areas as well as add a grain
- Foil stamp text or design elements
- Apply a metal inlay

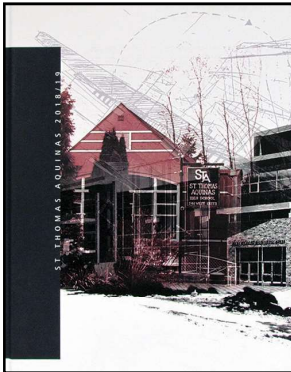
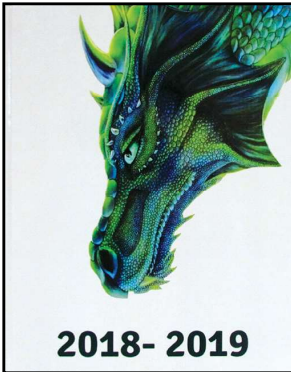
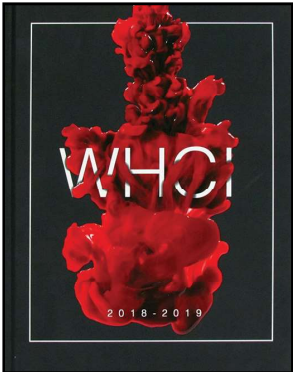
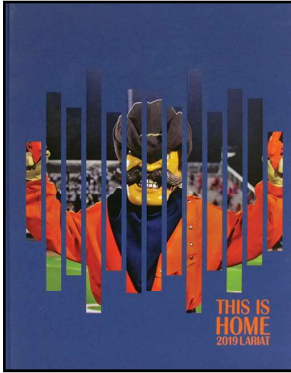
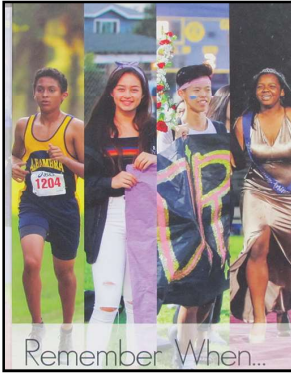
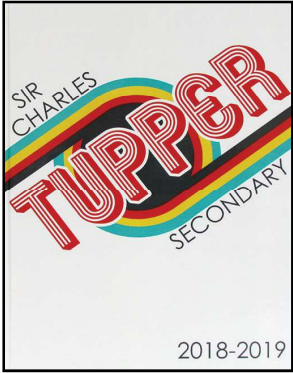
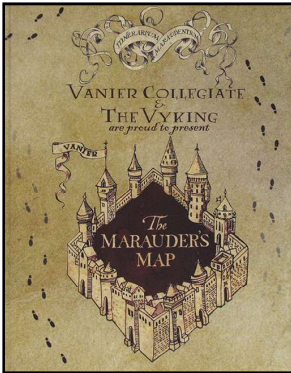
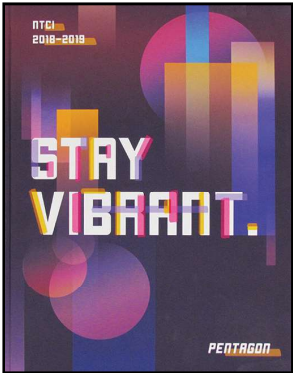

TEXTURED LINE

Textured Line offers a leather-like alternative to Crystalline. Like Crystalline, the Textured Line cover material is included in the base price of a hard cover yearbook. Textured Line is used to achieve a traditional looking cover. Designs for Textured Line covers should use clean, simple lines with not a lot of fine detail. Application options include:

- Silkscreen solid areas of ink in almost any color including metallic silver and gold
- Emboss or deboss areas as well as add a grain
- Quarter binding two colours of textured stock to achieve a traditional look
- Apply a metal inlay
- Foil stamp text or design elements

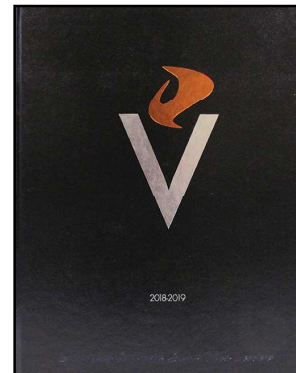
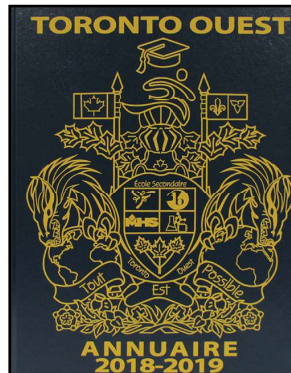
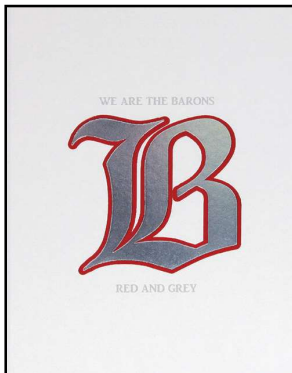

SPECIAL ORDER MATERIALS

Friens offers several special order cover materials. Sueded, Tanalin, Brillianta, Pearl Linen and Rainbow are a few of the cover materials available upon request. These materials have minimum quantity requirements and carry additional charges. Check with your Yearbook Consultant for pricing.

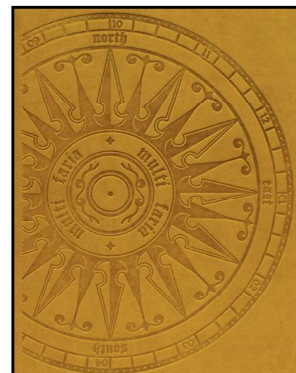

EMBOSSSED GRAINS

Embossed grains can be applied to both Crystalline and Textured Line covers. If your cover already has some custom embossing, the grain can be added for no additional charge.



FOX FUR

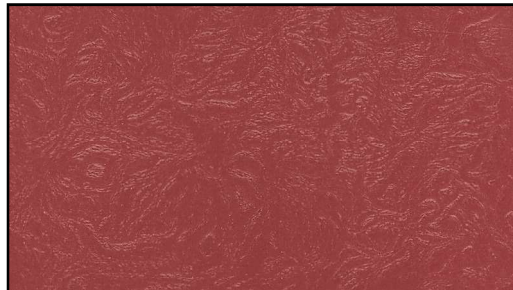

LAVA



BURLAP

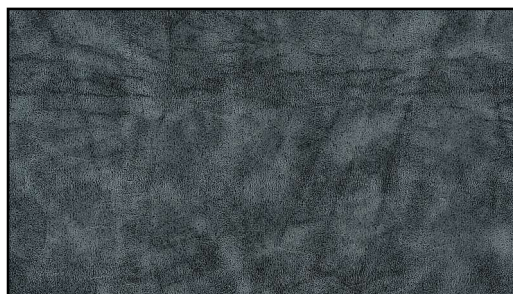

MISSION



PEOPLE

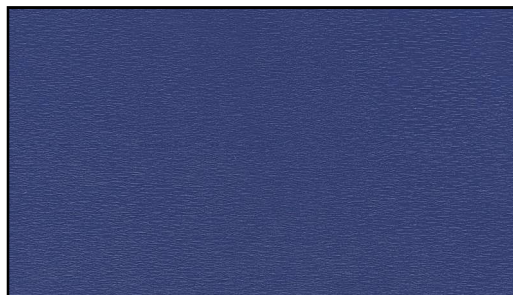

PIGSKIN



WALRUS

FOIL STAMPING

Foil stamping is a very popular method of applying traditional cover designs. It can add class and style to the right cover design. Many schools choose to combine foil with one or more silkscreen ink colors or a full process color cover for a unique effect. The two standard foil colours are gold and silver but there are many other available for special order.

There are many design possibilities when using foil but there are also some guidelines to remember. The foil is applied by heat and pressure to the

cover and in order to achieve proper adhesion, your design should avoid any large, solid areas. Clean, well defined lines work best. Avoid designs with a lot of detail and very fine lines because the foil may fill in these areas and the detail could be lost. Any design using foil on the back cover uses a larger die, therefore the cost is greater.

Check with your Yearbook Consultant to make sure the design you've chosen will work successfully with foil, and for a cost estimate.

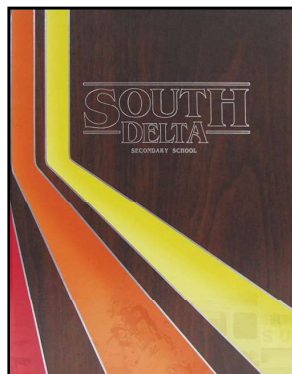
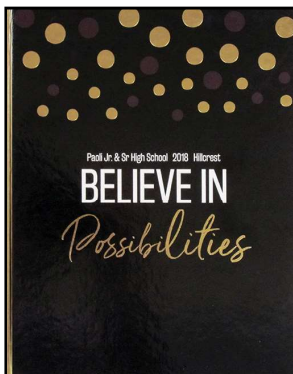
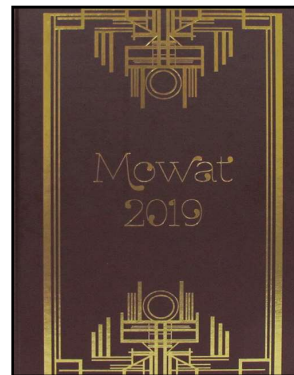
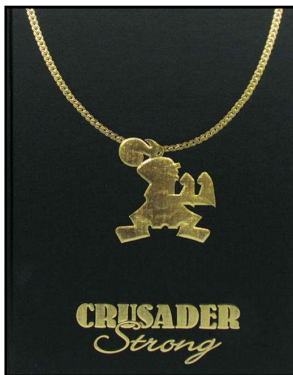
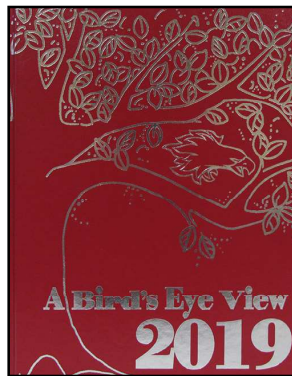
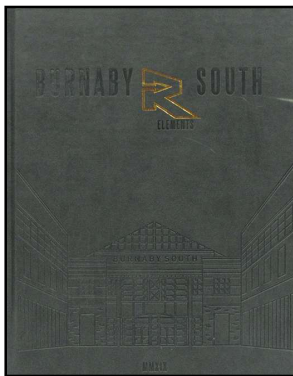

EMBOSSING

EMBOSSING OPTIONS

- **Flat Embossed:** Embossing artwork is raised to one level. Artwork and text may be printed within the raised area. The text can be included in the raised area or formed as individual raised letters outside of the raised area.
- **Multi-level Flat Embossed:** Embossing artwork can be raised to a few different levels, or items debossed to appear pressed in the cover.
- **Sculptured Embossed:** The raised image area has a definite three dimensional look and feel. If ink is not applied to the 3D area, it is referred to as blind embossing.
- **3D Metal Inlay:** This application combines the application of a heavy foil and a sculptured embossing. The effect can be compared to the look of a metal coin.

COVER BOARD WEIGHT

Hard cover 8.5" x 11" yearbooks use a standard 100 pt. board in the cover. For 9" x 12" books, and some of our specialty packages, 120 pt. is the standard weight. Embossed covers use a 150 pt. board. A thicker cover board gives the book more bulk and protection. Heavier board can be specially ordered for any hard cover book

PERSONALIZATION

The cover area used for personalizing will be a flat area with no grain added. This will eliminate the chance of the foil breaking up and make the type easier to read.

CUSTOM DIES

Ask Friesens to store your custom embossing die so that it can be used year after year, saving you the cost of ordering new dies.

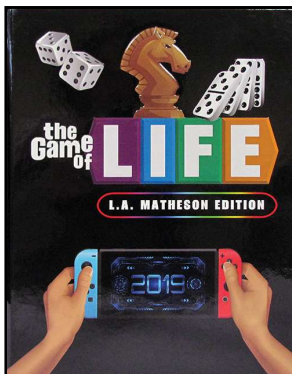
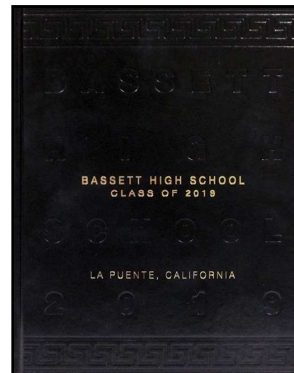
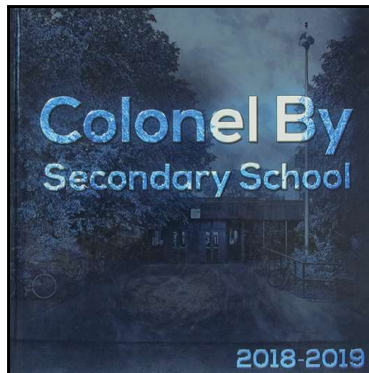
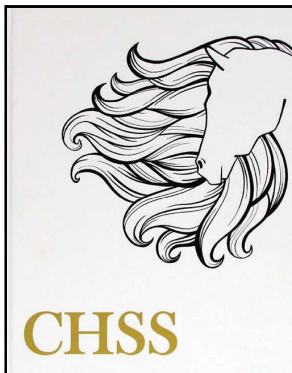



**STOCK
COVER
SHOWROOM**

STOCK PROCESS COVERS AND ENDSHEETS

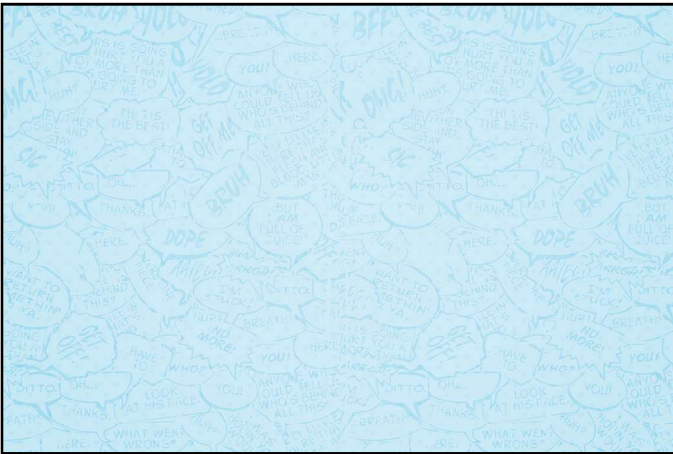
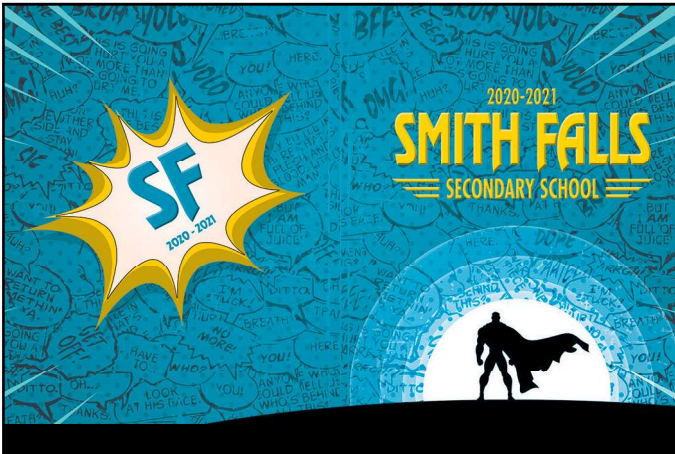

20-HERO

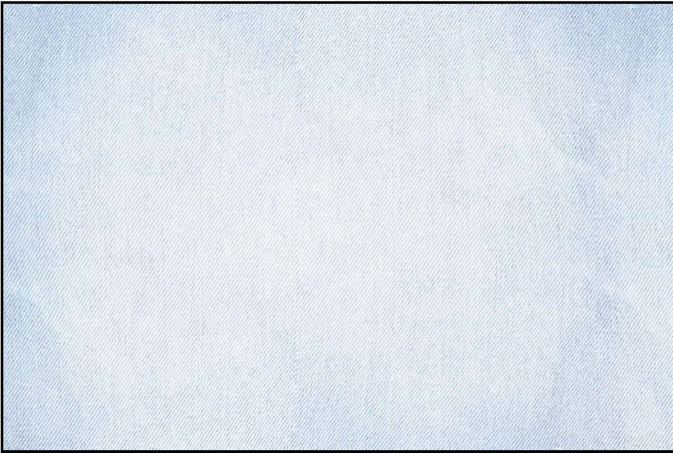
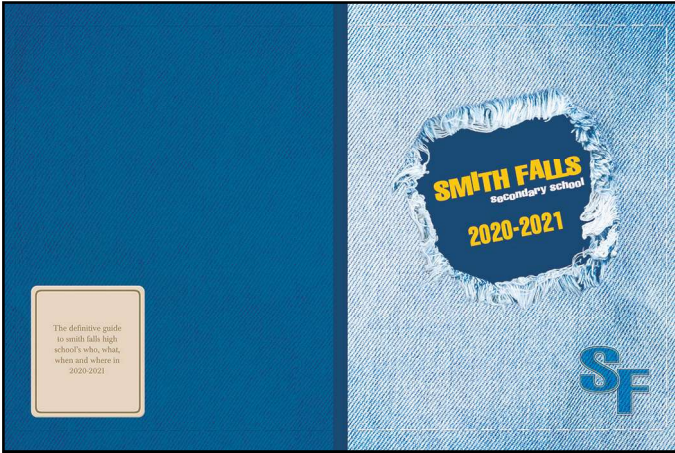

20-JEANS

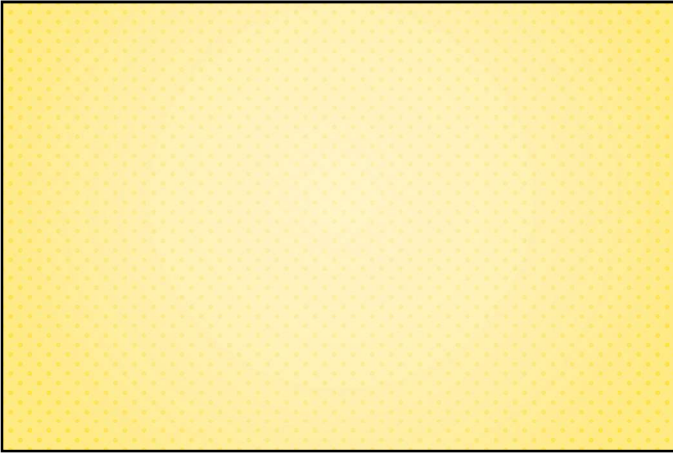

20-KAPOW

STOCK PROCESS COVERS AND ENDSHEETS

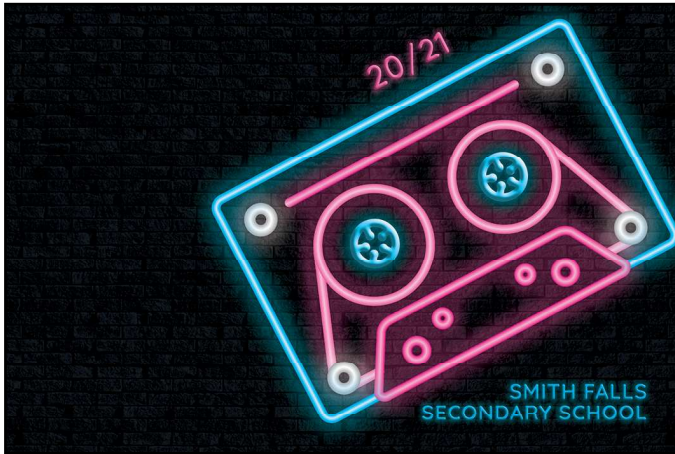

20-MIX TAPE

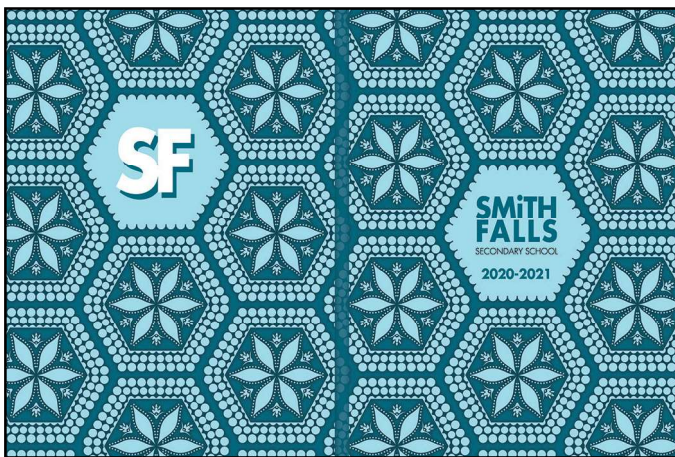
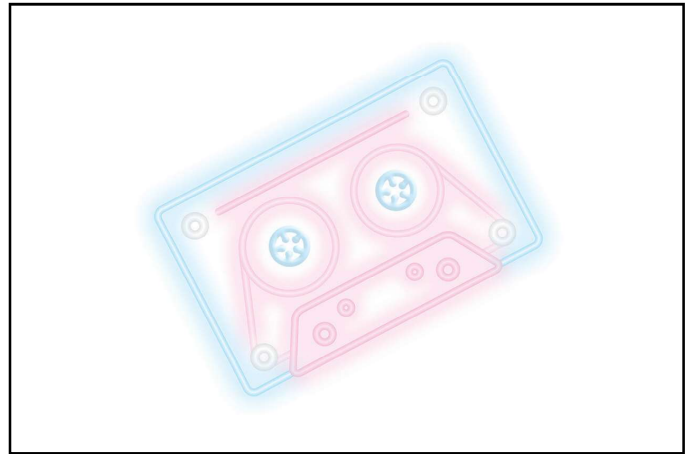

20-TAPESTRY

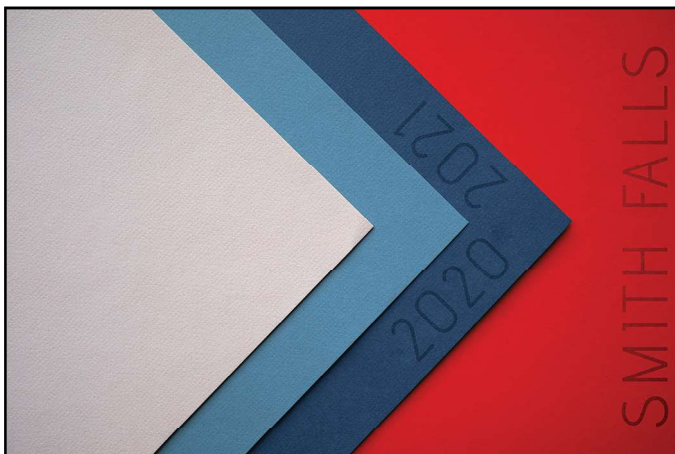

20-THE RIGHT DIRECTION



STOCK PROCESS COVERS AND ENDSHEETS

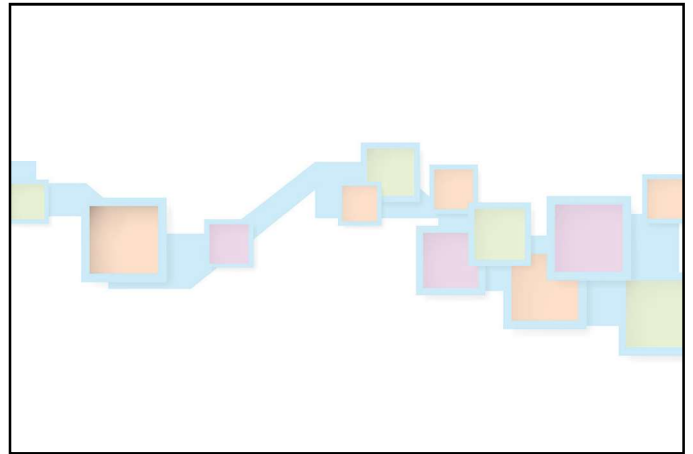
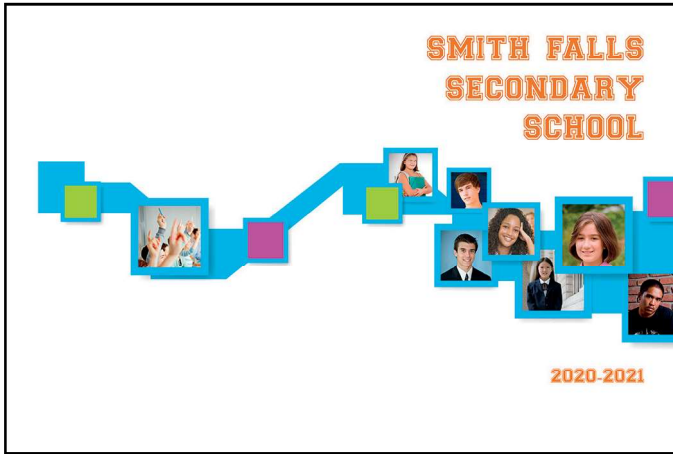

19-FEATURETTE

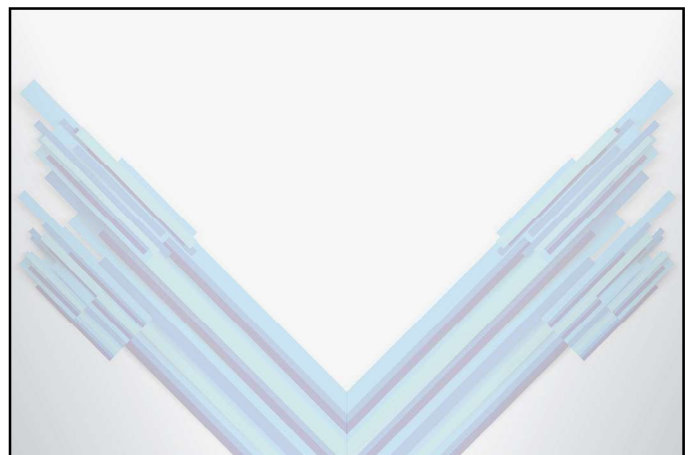

19-DROPDOWN



19-RAINBOW

STOCK PROCESS COVERS AND ENDSHEETS

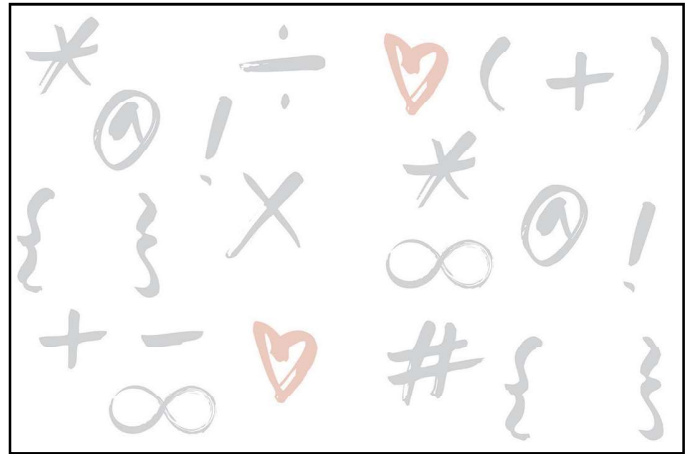
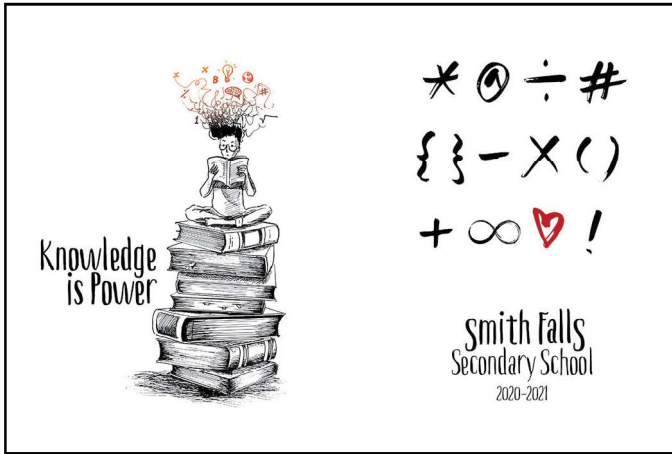

19-KNOWLEDGE

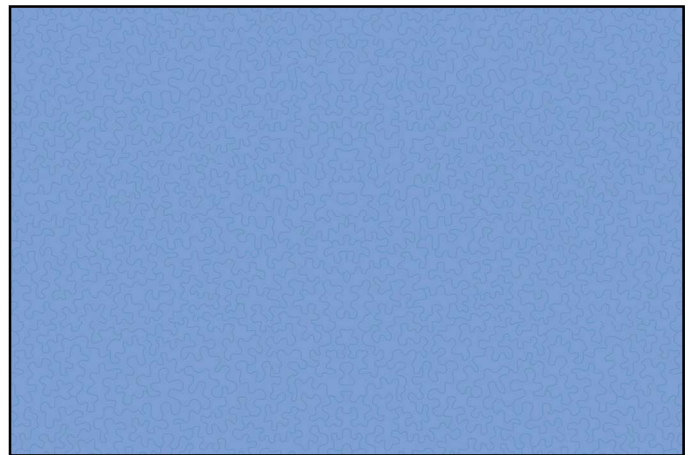
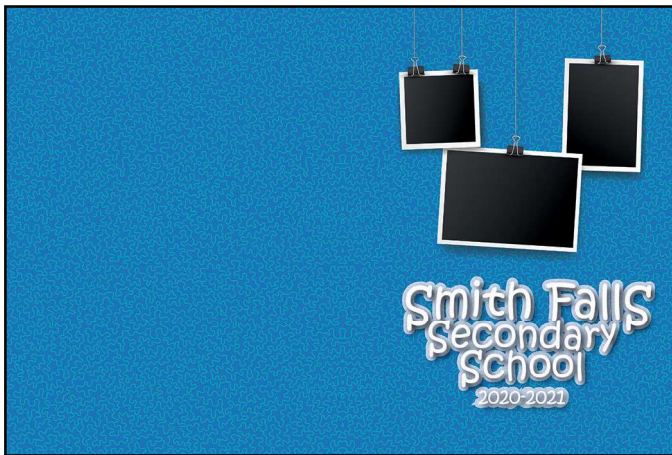

19-BY A THREAD

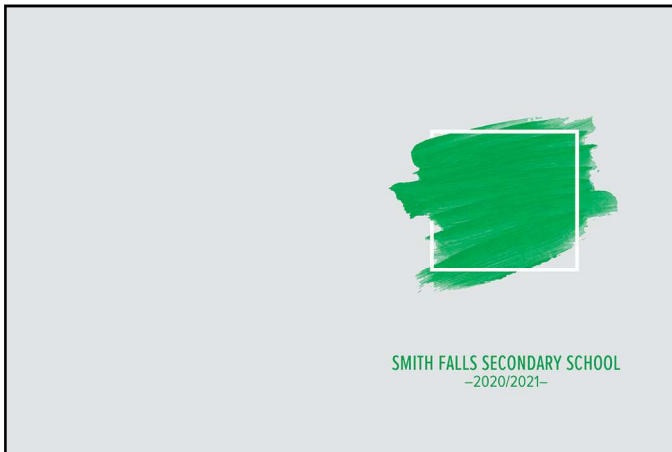

19-ACRYLIC

STOCK PROCESS COVERS AND ENDSHEETS

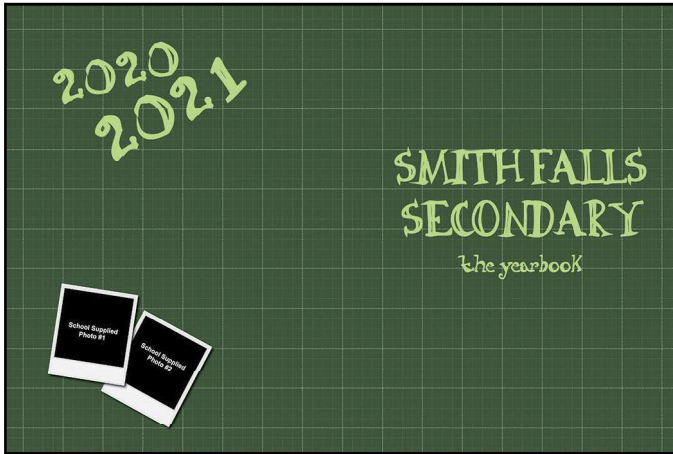

18-ALIGNED 1

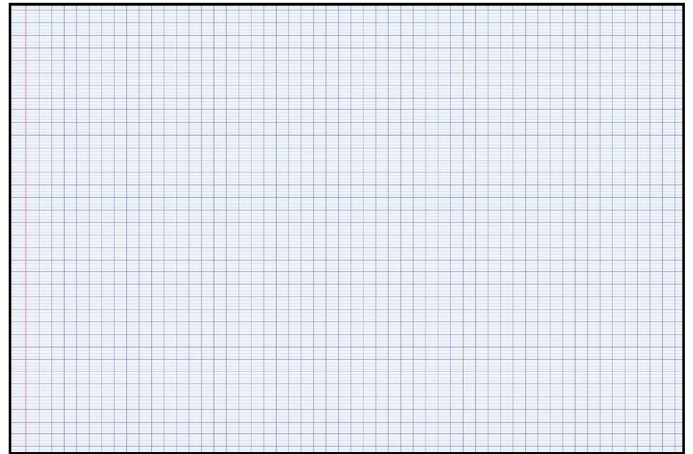

18-ALIGNED 2



18-ANDY

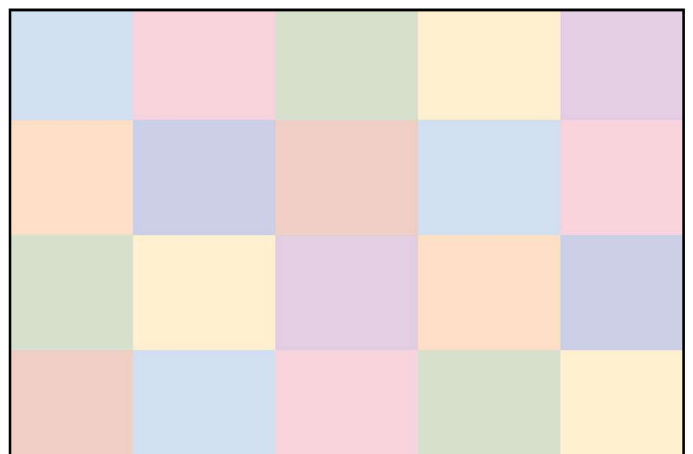

STOCK PROCESS COVERS AND ENDSHEETS

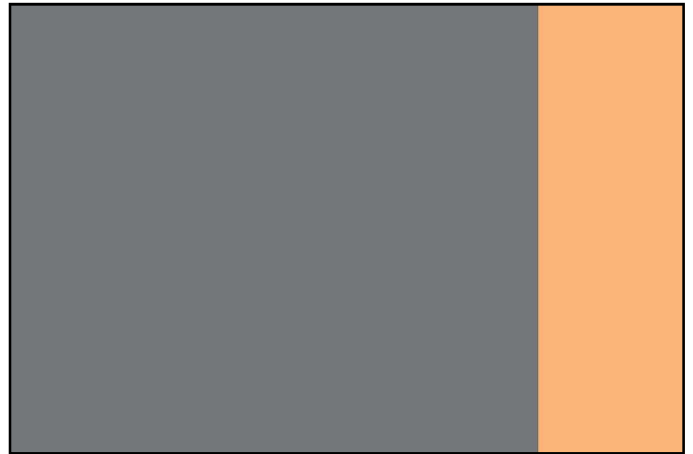
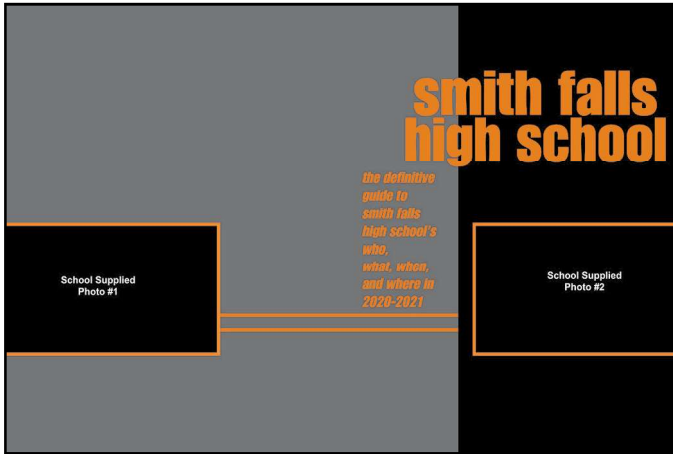

18-CALICO 1



18-CALICO 2

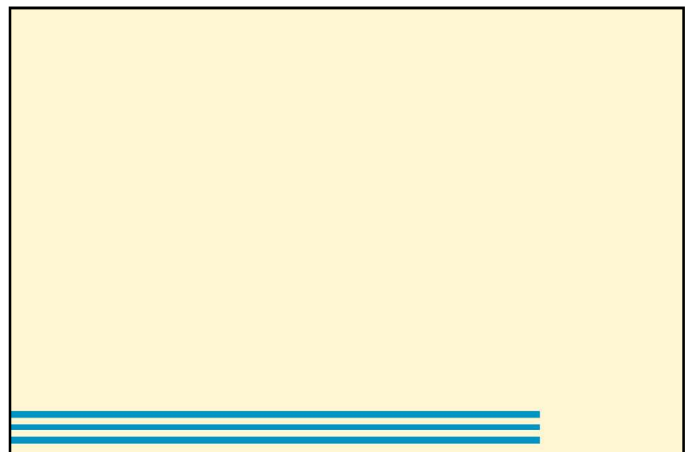
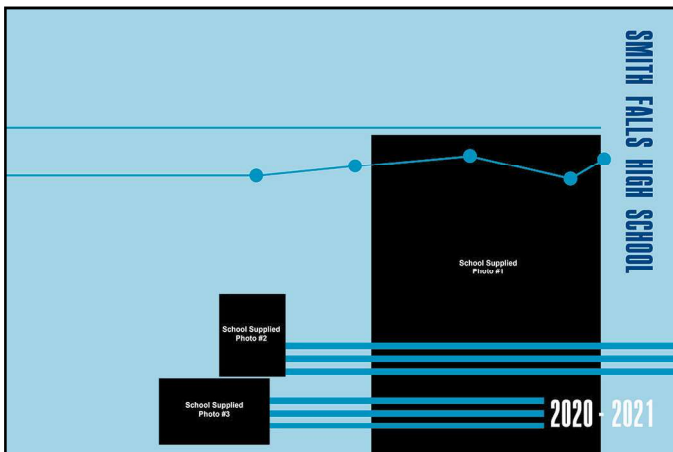

18-CONNECTED 1

STOCK PROCESS COVERS AND ENDSHEETS

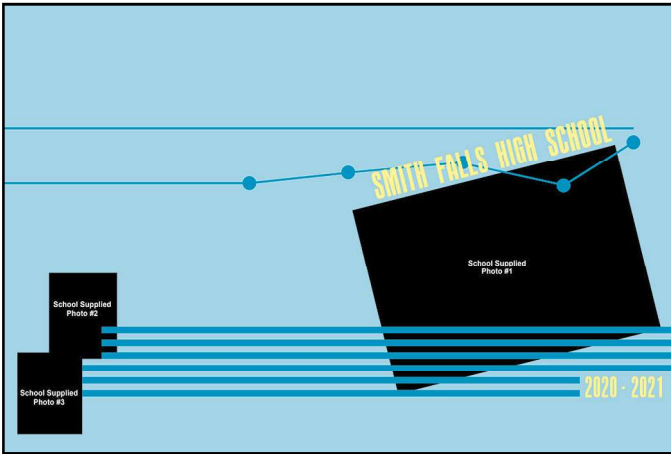

18-CONNECTED 2

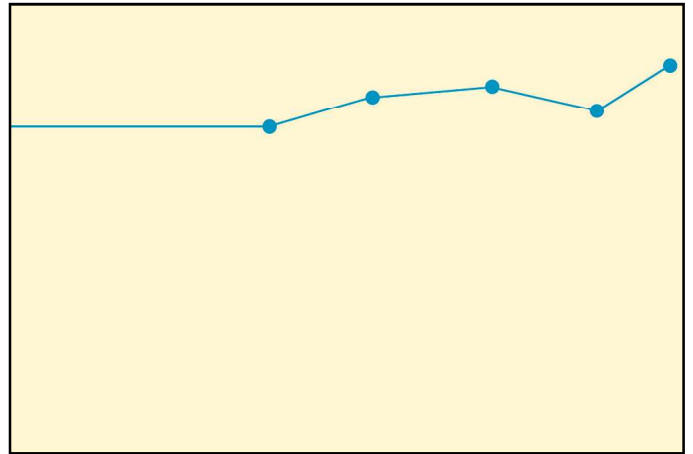

18-CRAFTED 1

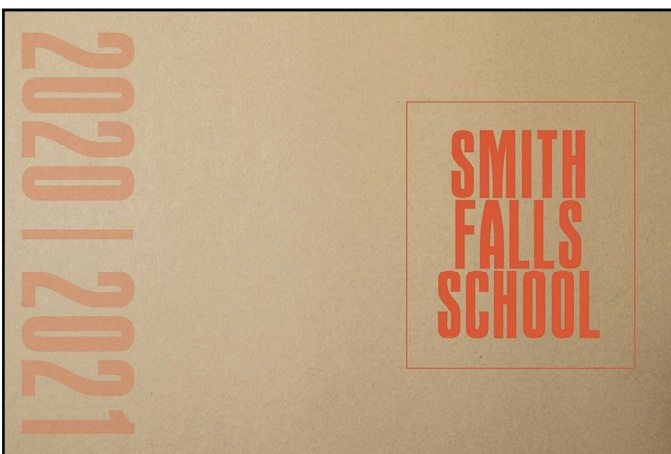

18-CRAFTED 2

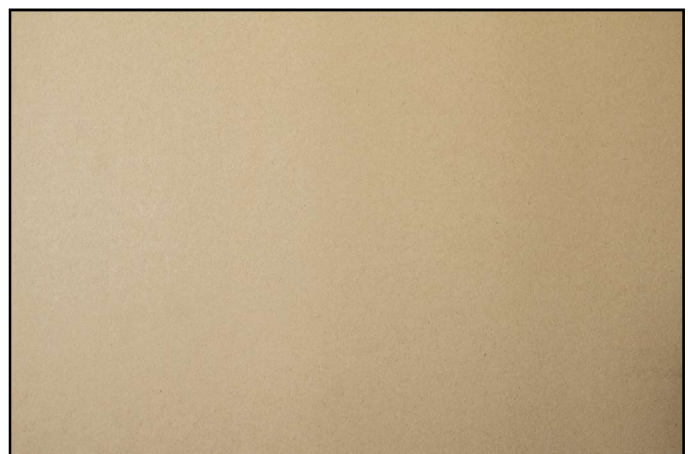

STOCK PROCESS COVERS AND ENDSHEETS



18-FRAMED MEMORIES 1

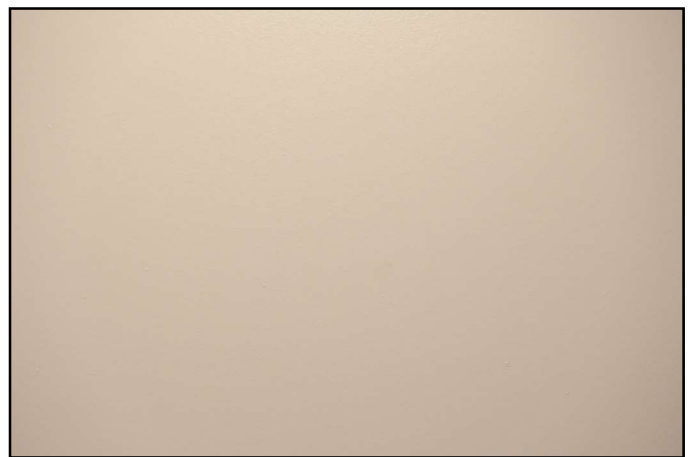
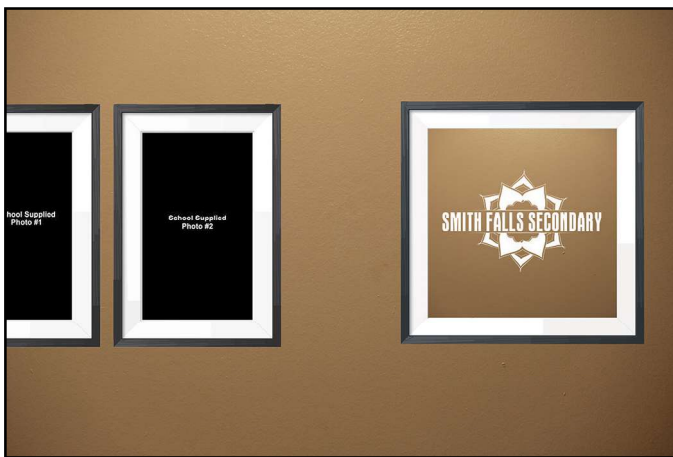

18-FRAMED MEMORIES 2

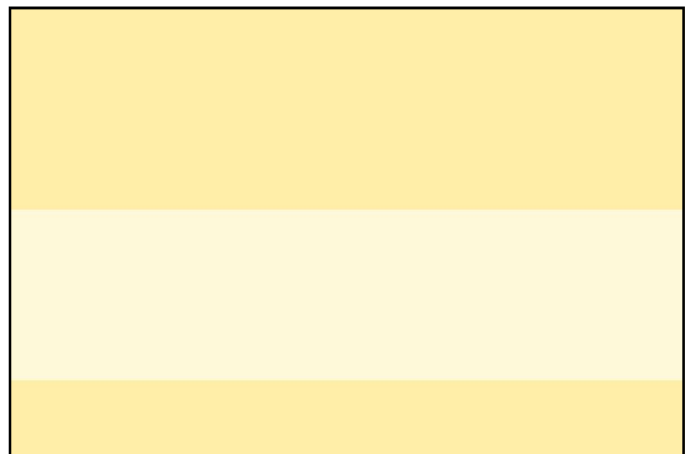
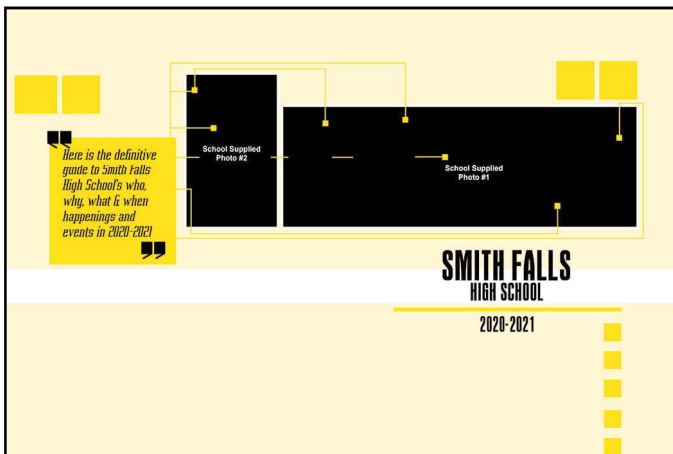

18-HIGHLIGHTED 1

STOCK PROCESS COVERS AND ENDSHEETS

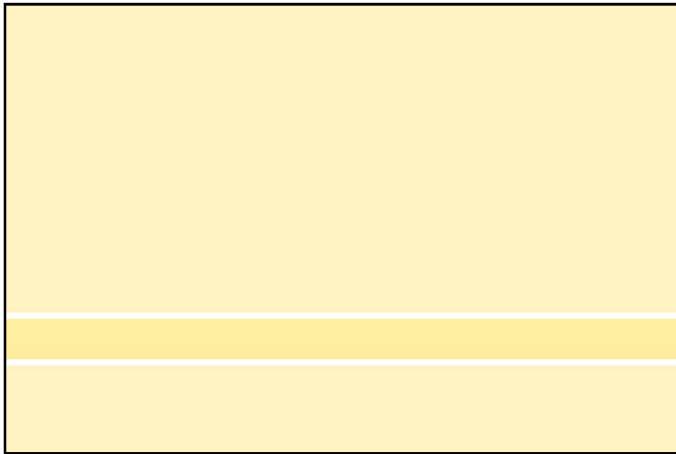
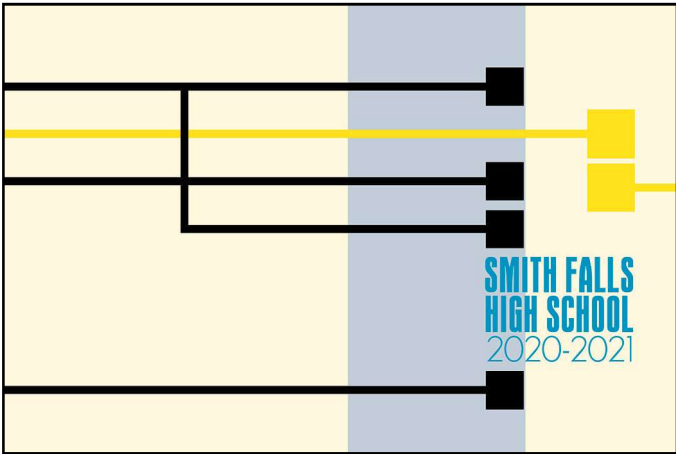

18-HIGHLIGHTED 2

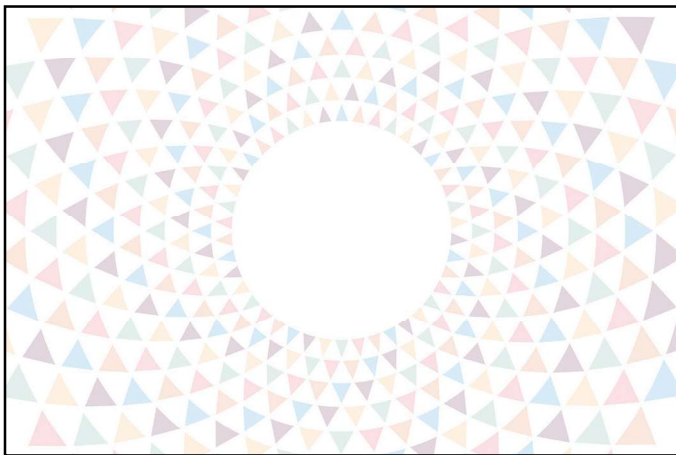

18-KALEIDOSCOPE

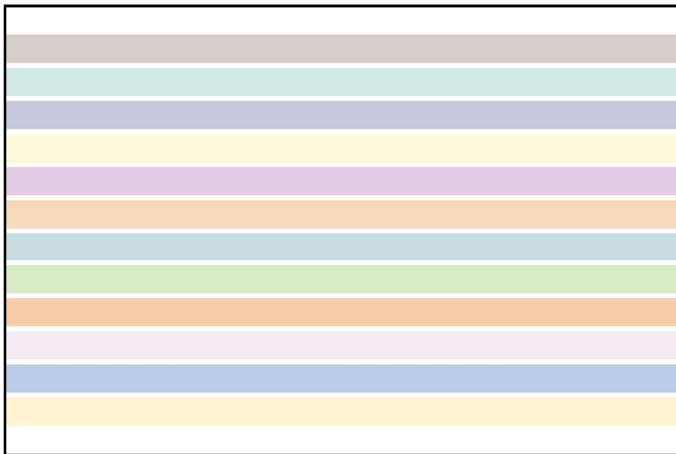
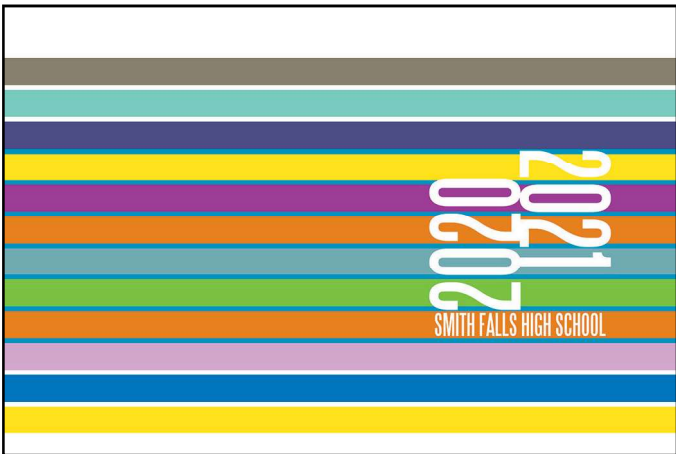

18-MAYPOLE 1

STOCK PROCESS COVERS AND ENDSHEETS

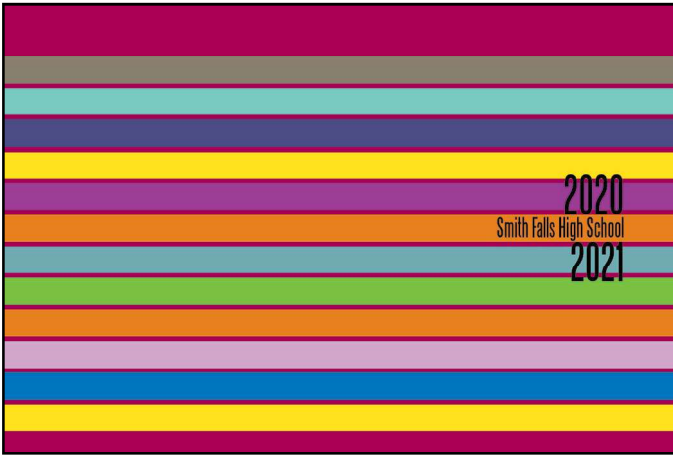

18-MAYPOLE 2

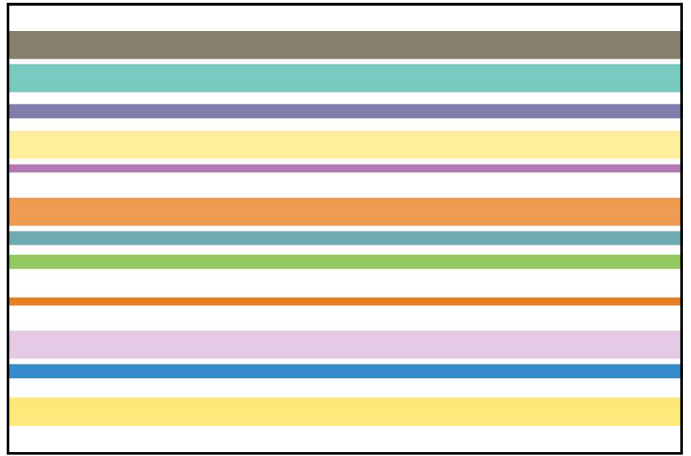

A Heading

Vol. 1 No. 1 C Heading 2020 - C Heading 2021 \$2.00

SMITH FALLS SECONDARY

School Supplied Photo #2

School Supplied Photo #1

C Heading

School Supplied Photo #3

Advertisement Text:

SMITH FALLS SECONDARY
 1000 Main Street
 Smith Falls, Ontario
 K7A 1R1
 Tel: (613) 253-2222
 Fax: (613) 253-2223
 Email: info@smithfalls.ca

18-NYT 1

CLASSIFIED

The Daily News 2020

CLASSIFIED

The Daily News 2021

Advertisement Text:

Announcements
 This section is for all types of announcements, including birth notices, obituaries, and community events.

Recreation/Leisure
 This section is for recreational activities, travel tips, and leisure-related news.

Services
 This section is for professional services, including legal, medical, and financial advice.

Education
 This section is for educational news, including school news, university admissions, and research findings.

Business
 This section is for business news, including market trends, company announcements, and economic news.

Employment
 This section is for job listings, career advice, and employment news.

For Sale
 This section is for items for sale, including real estate, vehicles, and household goods.

Travel - Sports
 This section is for sports news, travel tips, and recreational activities.

Travel - Environment
 This section is for environmental news, travel tips, and nature-related content.

Message
 This section is for general messages, letters to the editor, and community news.

Ovenem intemur

Vol. 1 No. 1 Date 2020 - Date 2021 \$2.00

SMITH FALLS SECONDARY

Da volectur, nit incho bla volorum in recae. Xeribus min plignatus.

School Supplied Photo #1

Advertisement Text:

SMITH FALLS SECONDARY
 1000 Main Street
 Smith Falls, Ontario
 K7A 1R1
 Tel: (613) 253-2222
 Fax: (613) 253-2223
 Email: info@smithfalls.ca

18-NYT 2

NEWS

EXTRA! EXTRA!

Advertisement Text:

SMITH FALLS SECONDARY
 1000 Main Street
 Smith Falls, Ontario
 K7A 1R1
 Tel: (613) 253-2222
 Fax: (613) 253-2223
 Email: info@smithfalls.ca

STOCK PROCESS COVERS AND ENDSHEETS

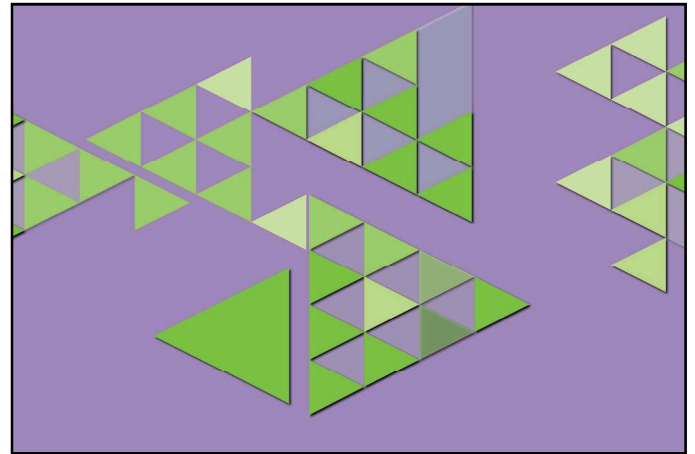
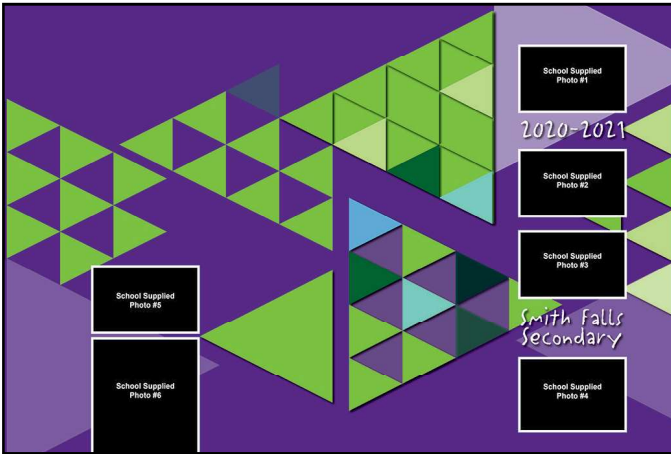

18-ONWARD 1

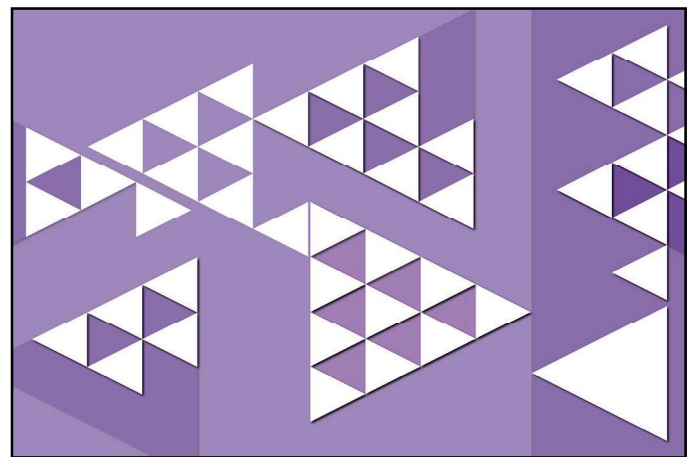
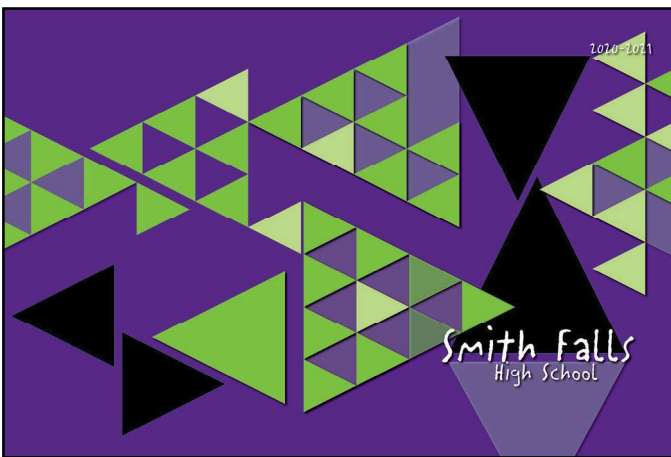

18-ONWARD 2

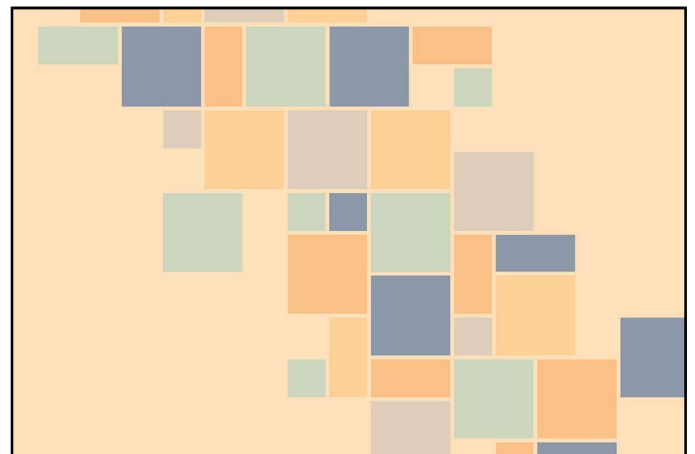
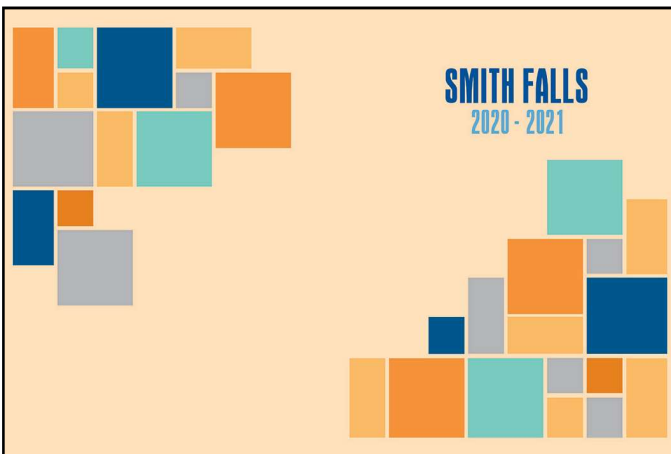

18-RETRO RECTANGLES 1

STOCK PROCESS COVERS AND ENDSHEETS

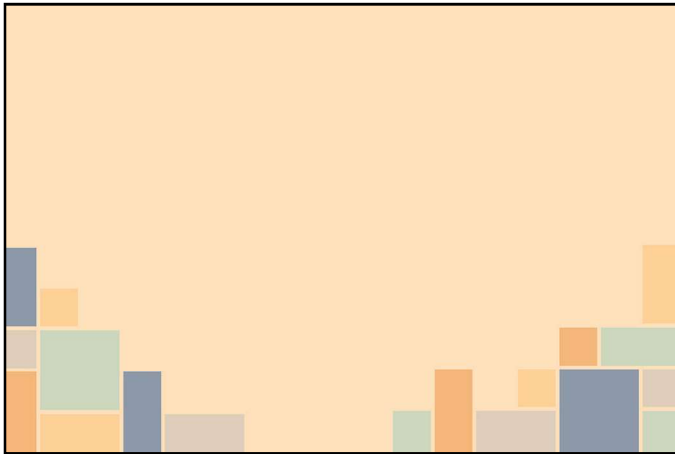

18-RETRO RECTANGLES 2

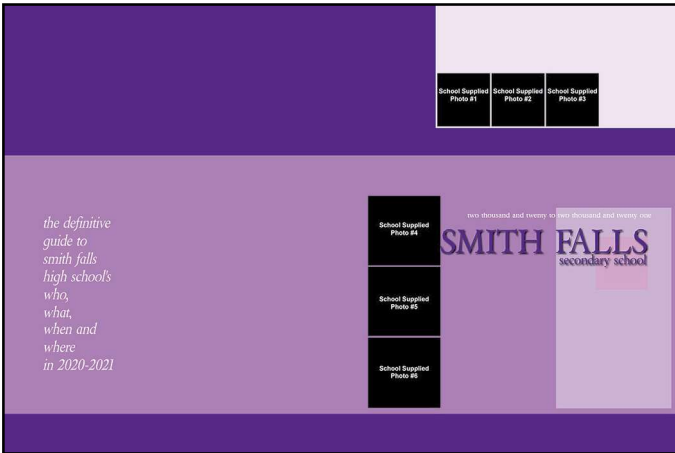

18-TINTED 1

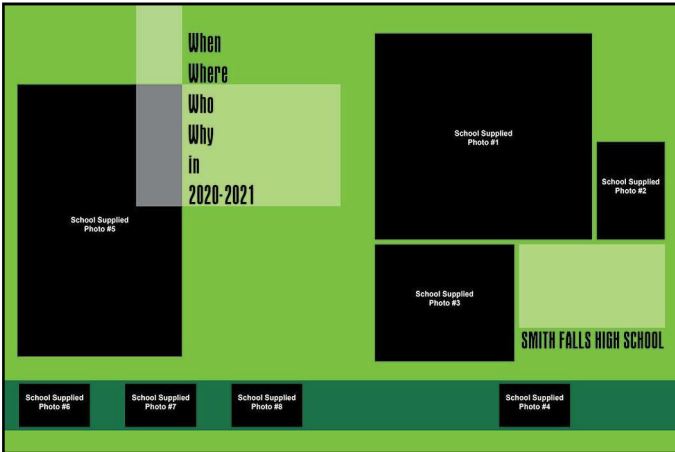

18-TINTED 2

STOCK PROCESS COVERS AND ENDSHEETS

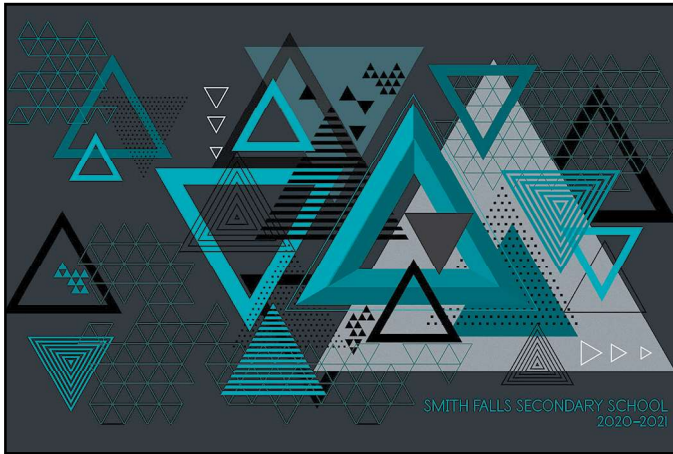

18-TRILOGY

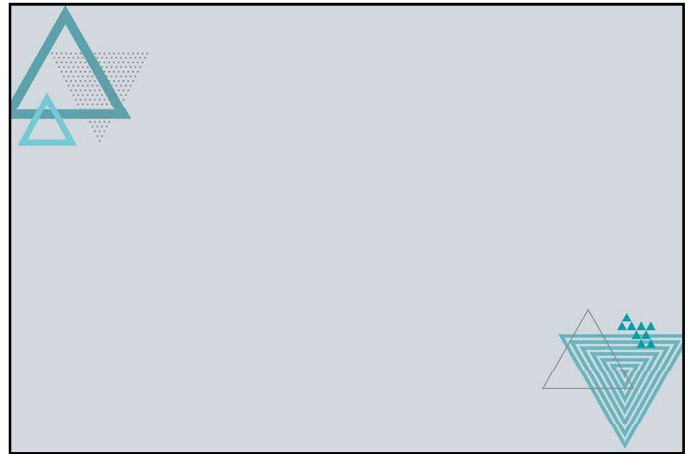

17-ACES

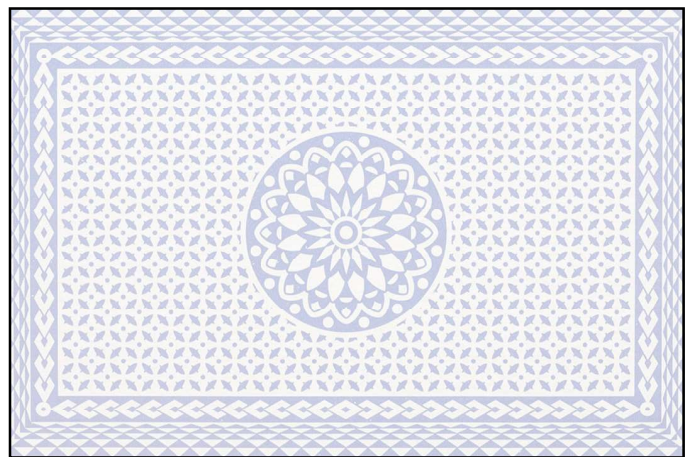

17-RETRO RAINBOW



STOCK PROCESS COVERS AND ENDSHEETS



17-WHAT WE ARE 1970



17-WHAT WE ARE 1980



16-BULLETIN BOARD



STOCK PROCESS COVERS AND ENDSHEETS



16-CARNIVAL

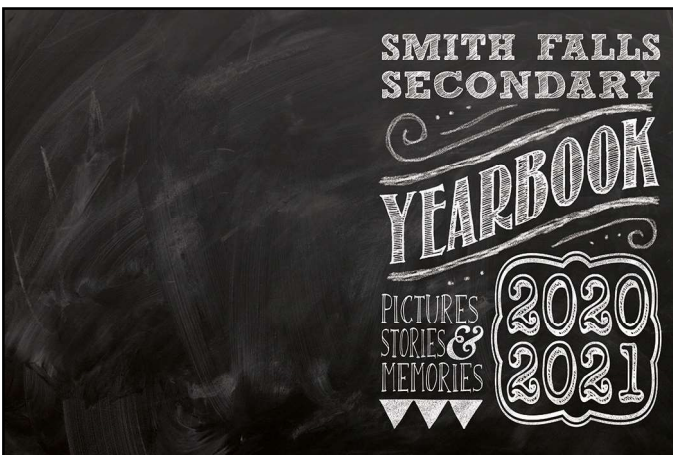

16-CHALKBOARD

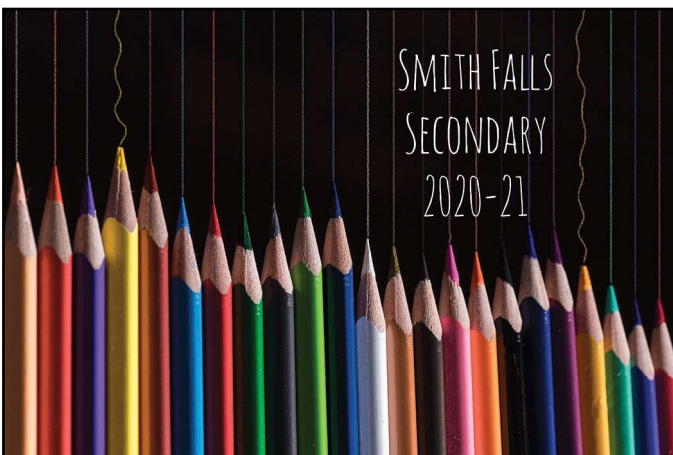

16-TRUE COLOURS



STOCK PROCESS COVERS AND ENDSHEETS



16-CONCRETE

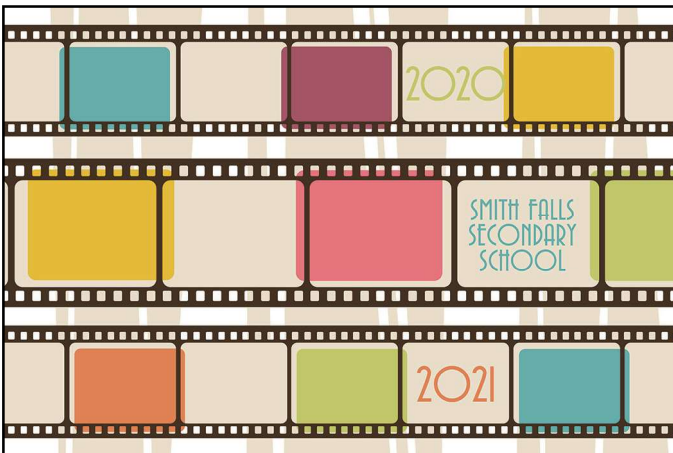

16-FILMSTRIP

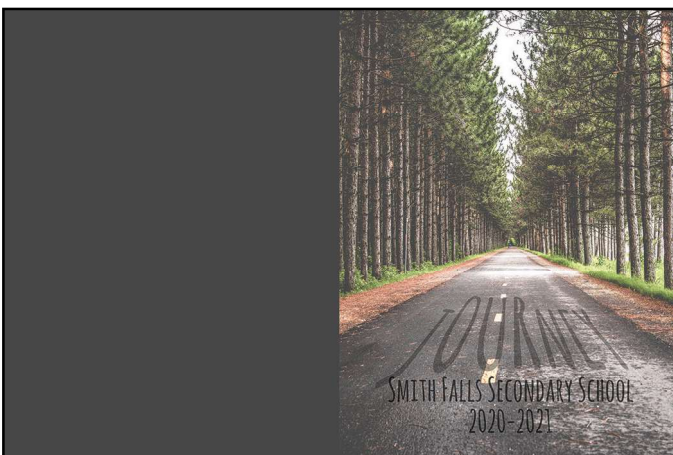
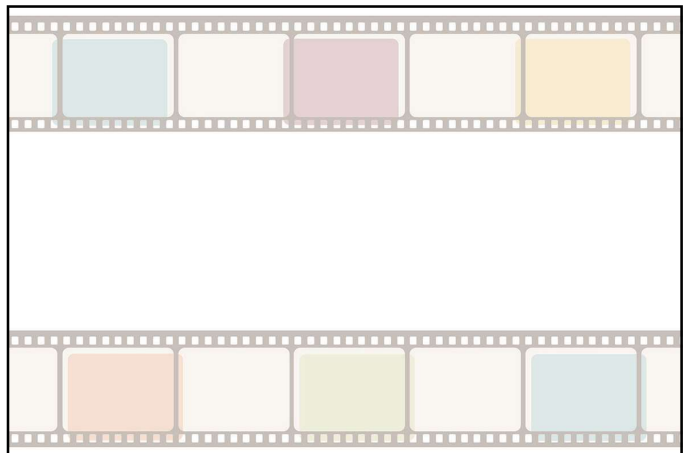

16-JOURNEY



STOCK PROCESS COVERS AND ENDSHEETS

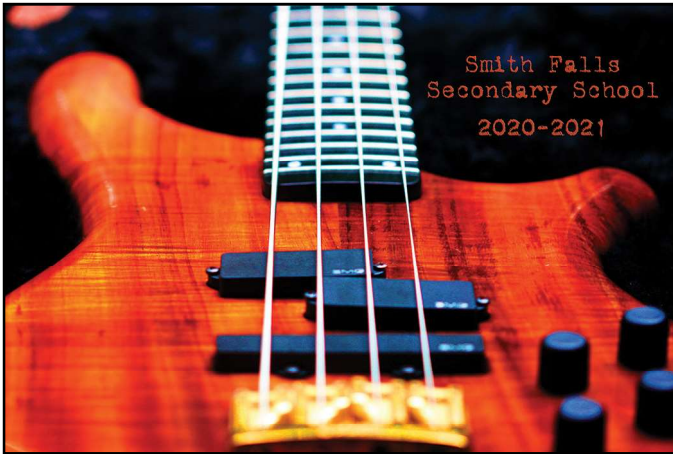

16-LET'S ROCK



16-LOTS A DOTS

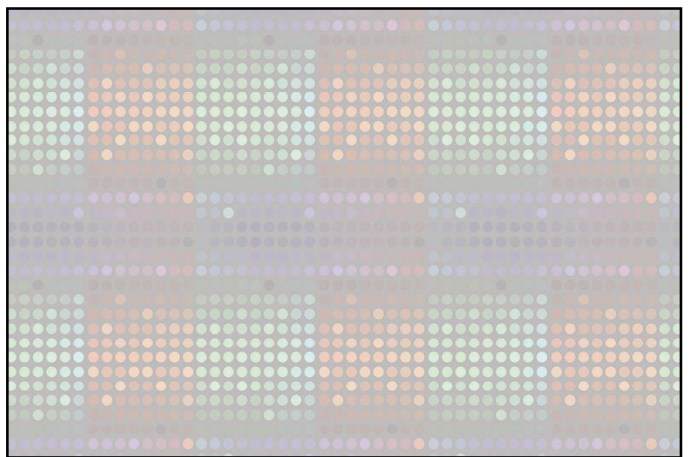

16-OFF THE RECORD



STOCK PROCESS COVERS AND ENDSHEETS



16-OH CANADA



16-SODA

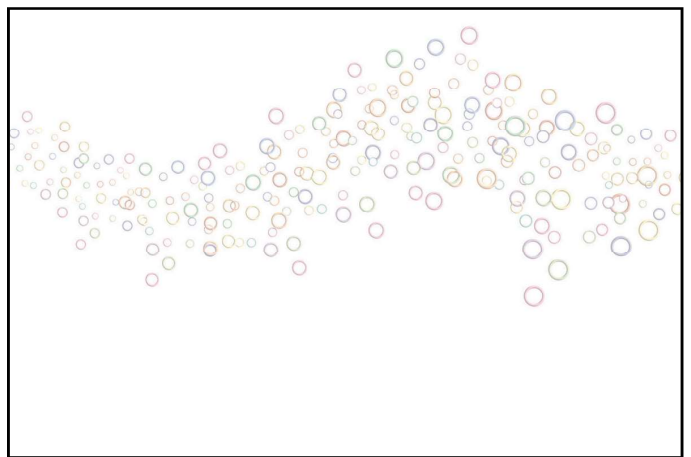

16-SOUNDTRACK

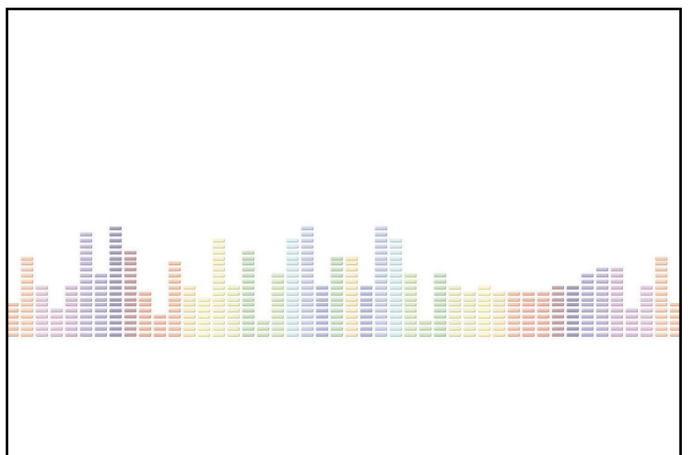

STOCK PROCESS COVERS AND ENDSHEETS



16-UNDER THE SEA



16-UP AND AWAY



16-WALK A MILE

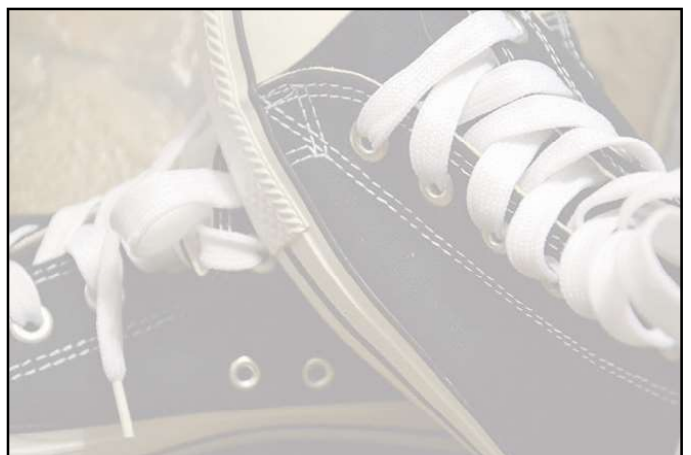

STOCK PROCESS COVERS AND ENDSHEETS



10-BLUEBERRY GUM

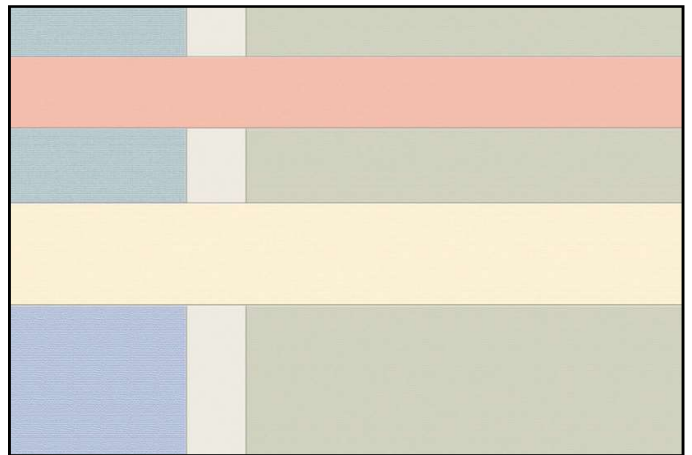
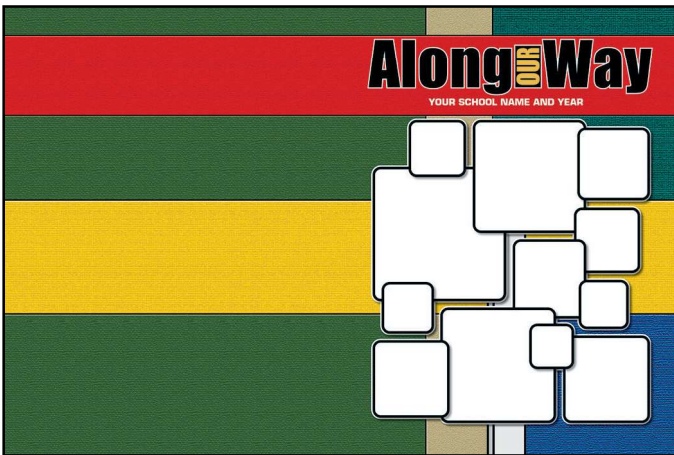

10-ALONG OUR WAY

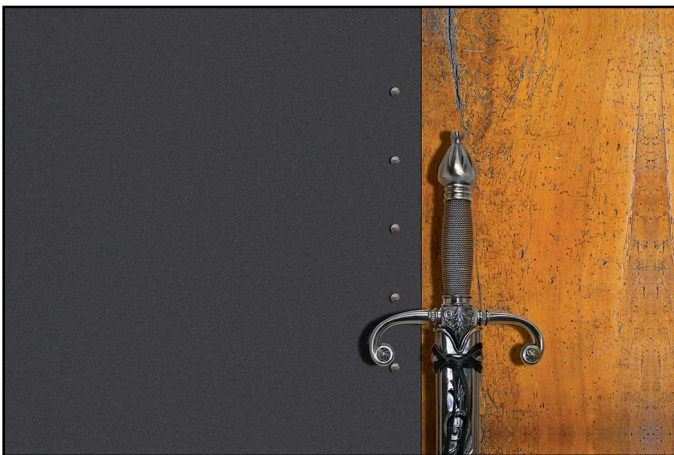

08-KNIGHT'S DAGGER

STOCK PROCESS COVERS AND ENDSHEETS



07-NATURAL TEXTURE



06-LEAVES

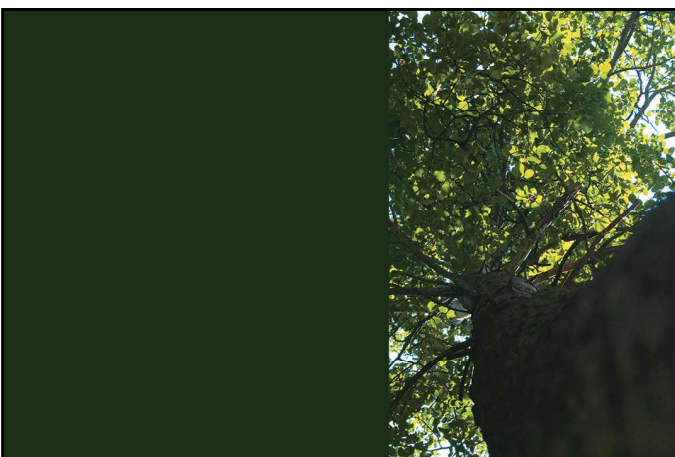
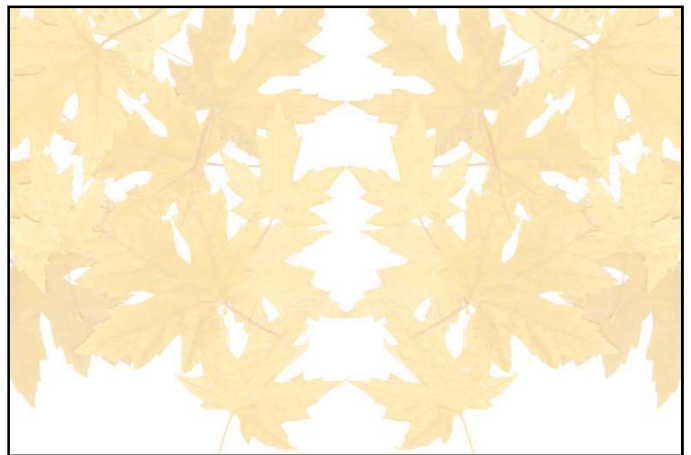

06-FRESH AIR



STOCK PROCESS COVERS AND ENDSHEETS

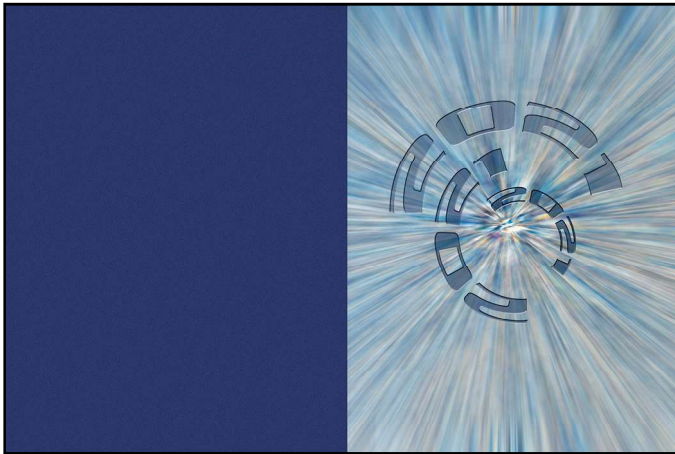

04-FAST FORWARD

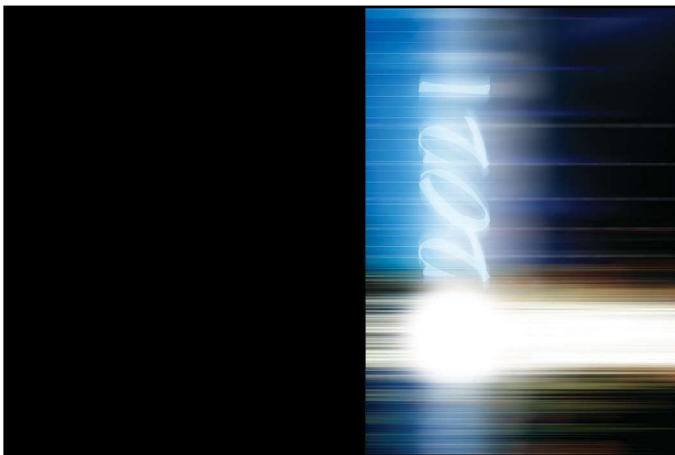
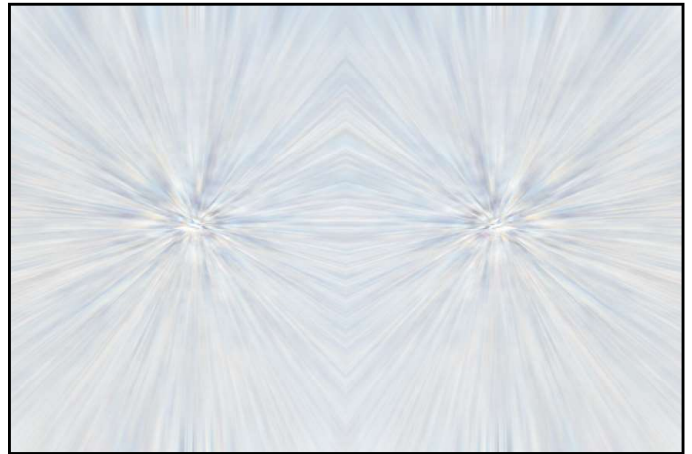

04-IN A FLASH

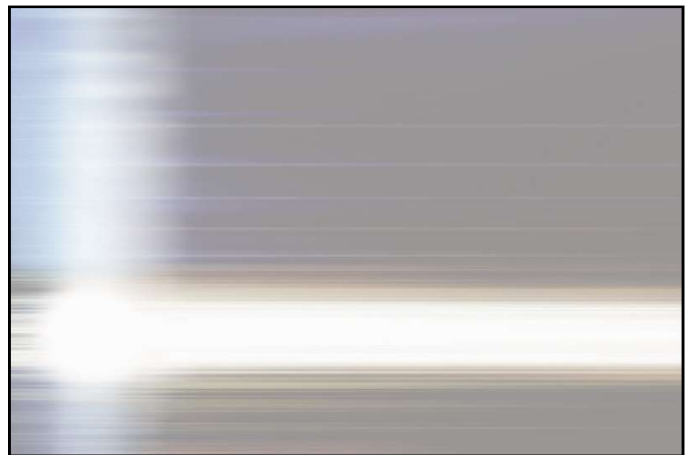

04-ANTIQUE LEATHER



ADDITIONAL STOCK COLOUR ENDSHEETS



04-SWIRLS



06-ANTIQUE BOOK

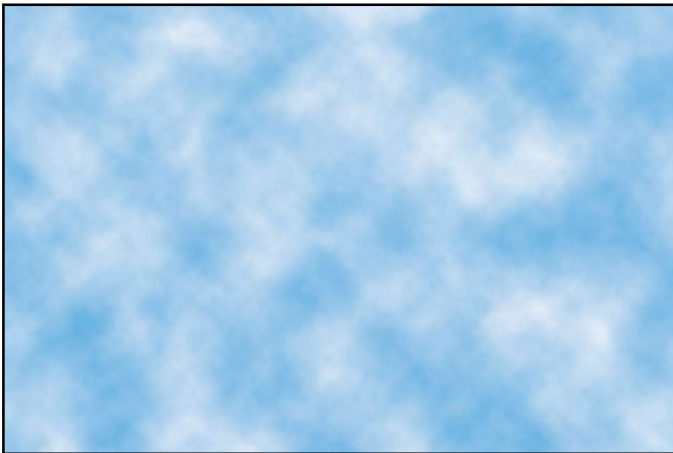

04-CLOUDS

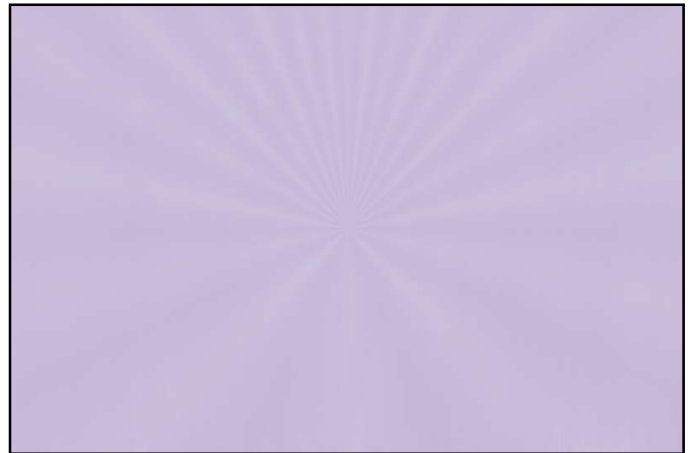

04-GRADIENT CENTRE



04-FOOTPRINTS



04-PAPER BAG

ADDITIONAL STOCK COLOUR ENDSHEETS

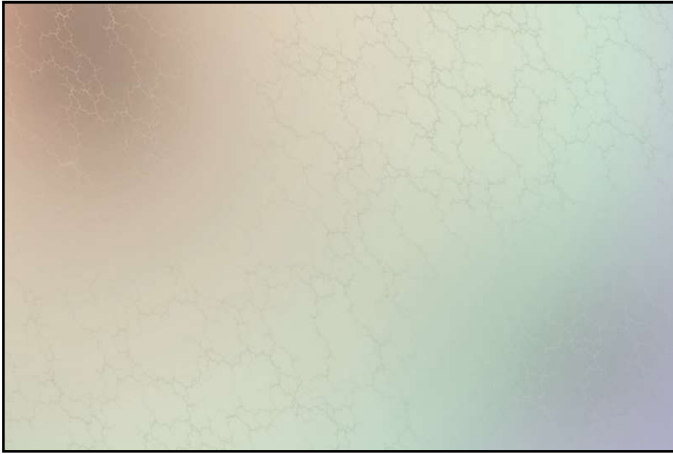

04-GRADIENT



16-PROM

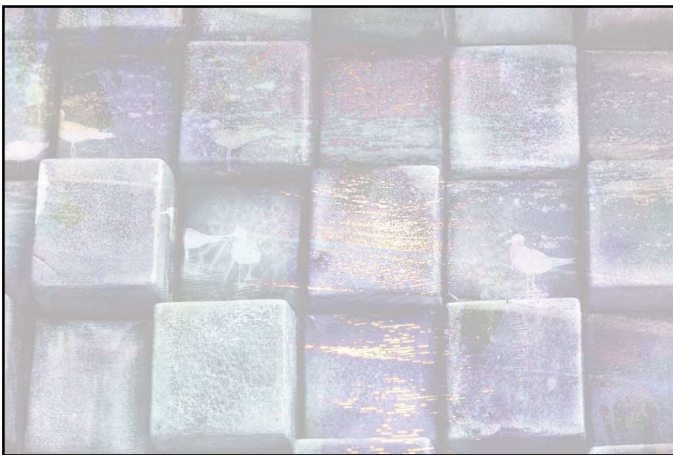

16-BIRDIE BLOCKS



16-BLUE RIDGE

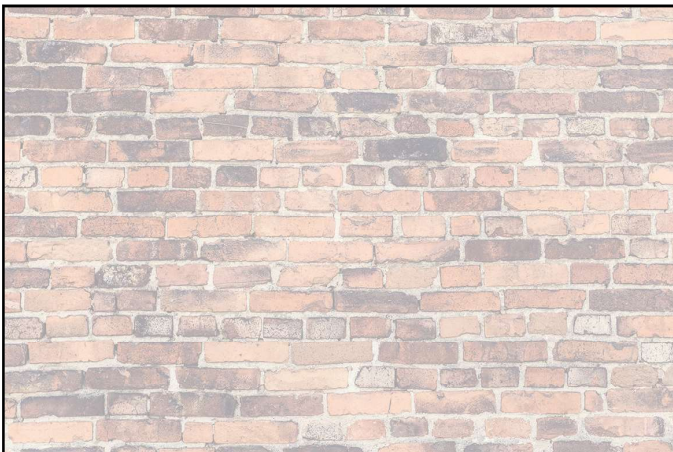

16-BRICK WALL



16-CELEBRATION

ADDITIONAL STOCK COLOUR ENDSHEETS



16-COOL BREEZE



16-CRAZY DAISY



16-GEARS



16-GIMME A SWING

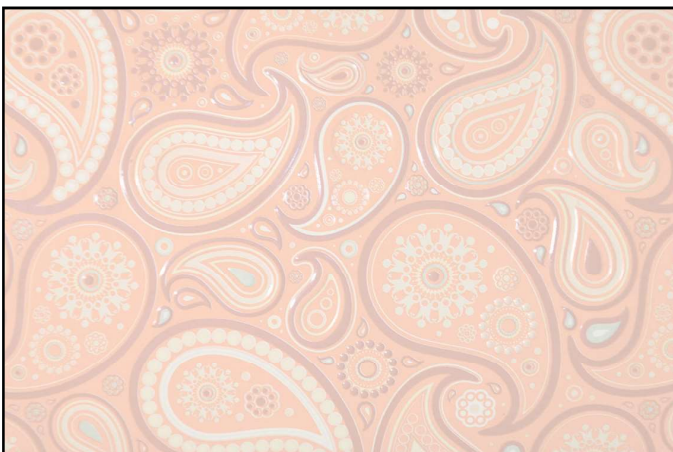

16-PAISLEY



16-PICTURES OF THE PAST

ADDITIONAL STOCK COLOUR ENDSHEETS



16-RAINBOW UMBRELLA



16-REAL STEEL



16-SPLASH

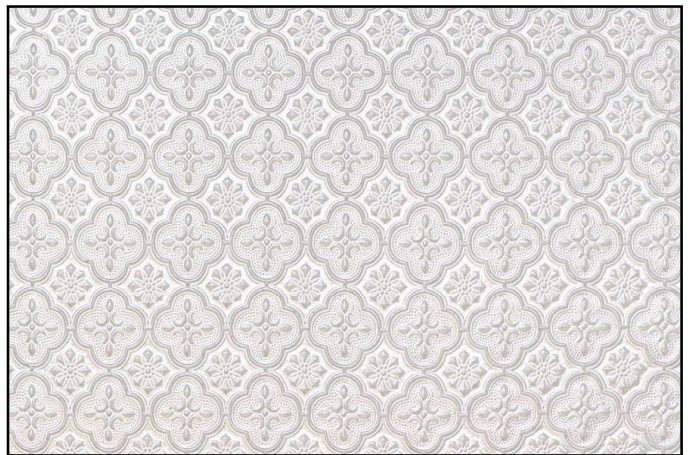

16-TIN TILE

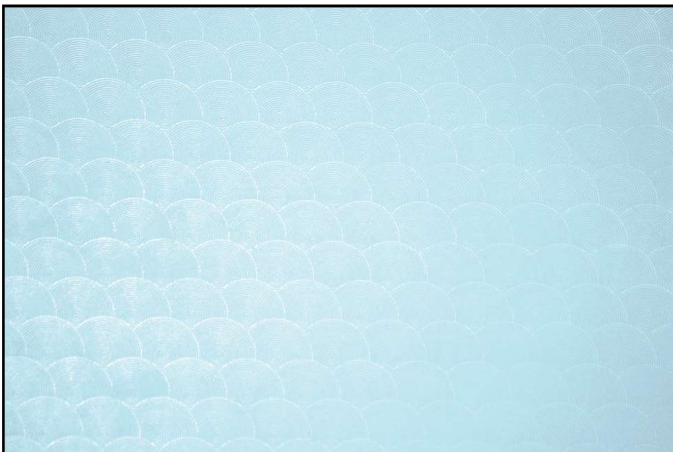

16-TURQUOISE RINGS



16-TWO TONE STONE

STOCK EMBOSSED COVERS

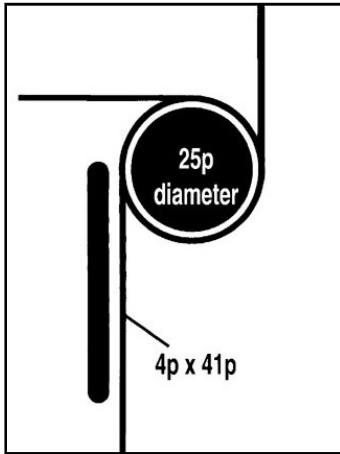

STOCK EMBOSS A



STOCK EMBOSS A-1

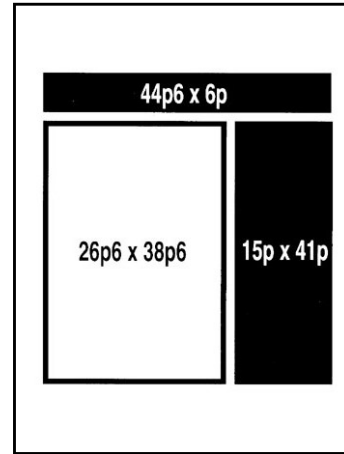

STOCK EMBOSS E-1

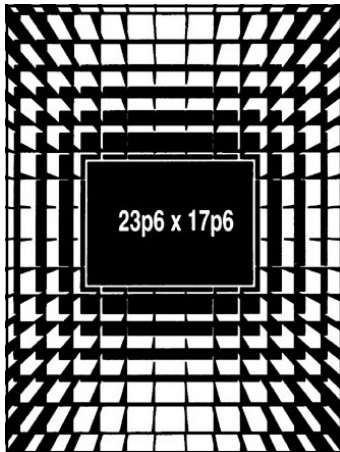

STOCK EMBOSS F

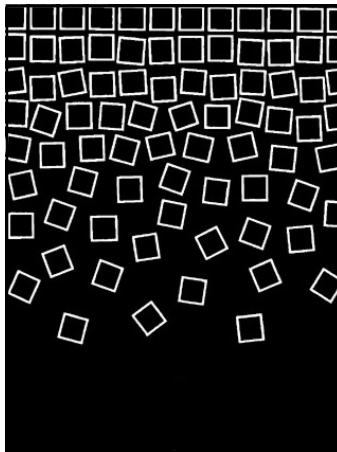

STOCK EMBOSS G

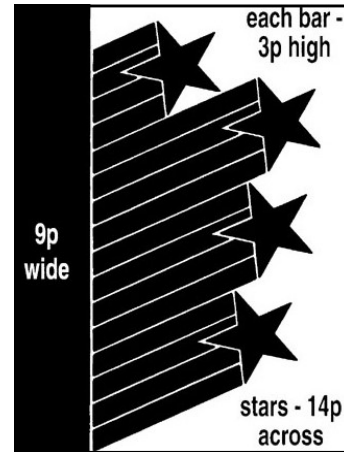

STOCK EMBOSS J

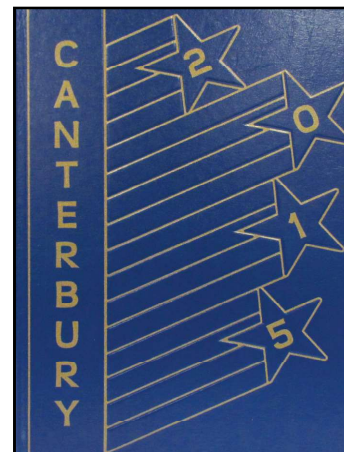

STOCK EMBOSSED COVERS

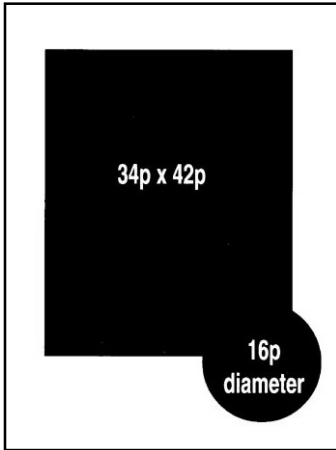

STOCK EMBOSS K-2

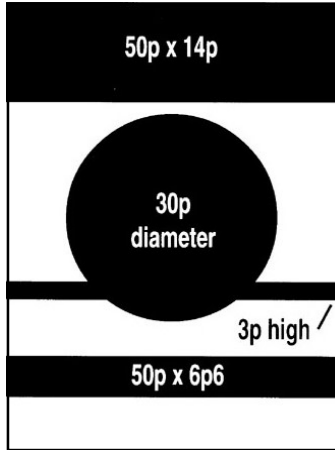

STOCK EMBOSS L

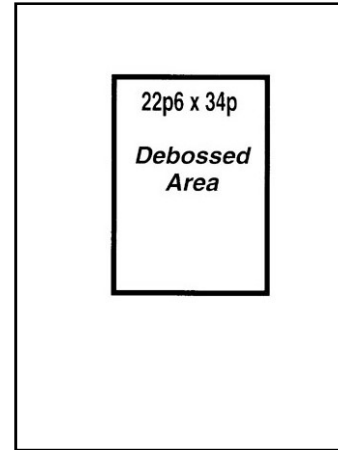

STOCK EMBOSS O

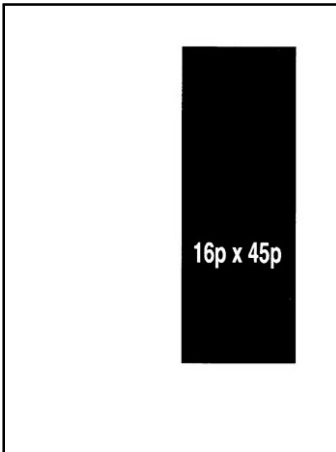

STOCK EMBOSS Q

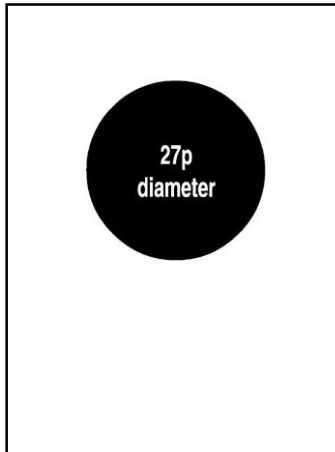

STOCK EMBOSS R

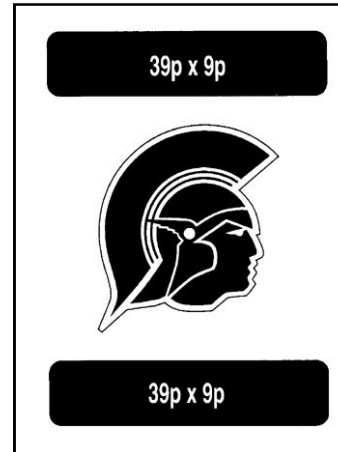

STOCK EMBOSS W

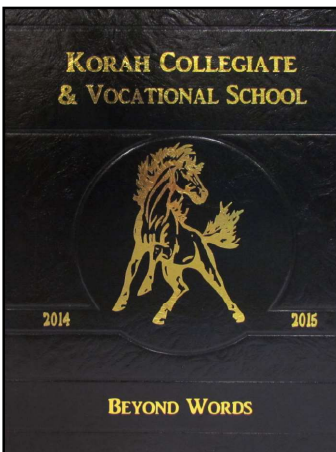

STOCK EMBOSSSED COVERS

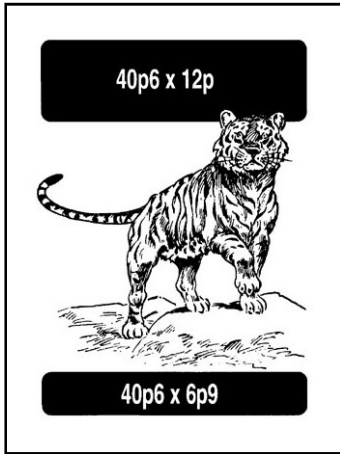

STOCK EMBOSS X

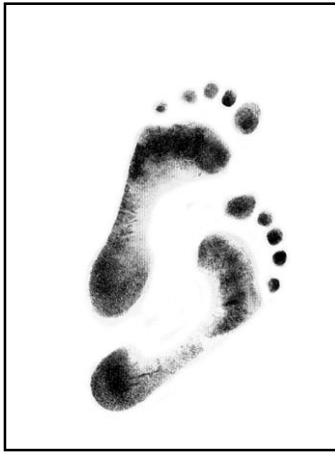

STOCK EMBOSS FEET

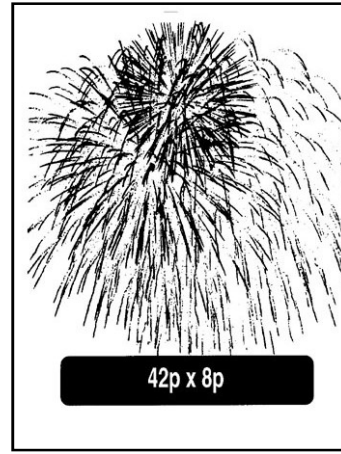

**STOCK EMBOSS
FIREWORKS**



**STOCK EMBOSS HOUR
GLASS**



**STOCK EMBOSS
SPIRAL**



**STOCK EMBOSS
VORTEX**

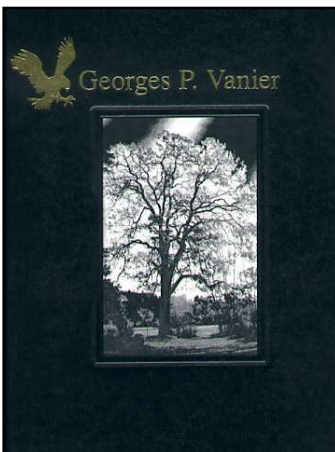
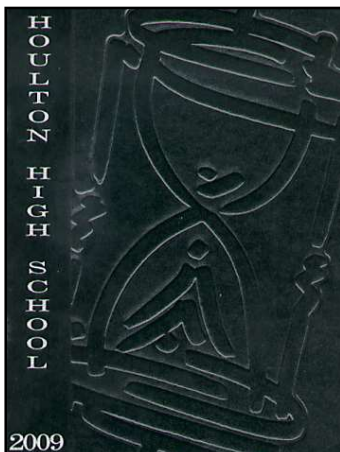

STOCK METAL INLAY DESIGNS

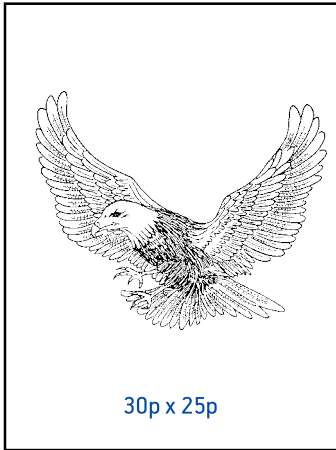

30p x 25p

**STOCK METAL
INLAY EAGLE**

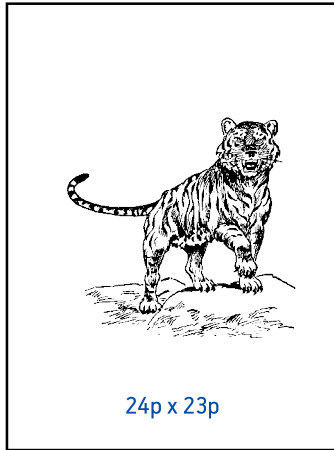

24p x 23p

**STOCK METAL
INLAY TIGER**

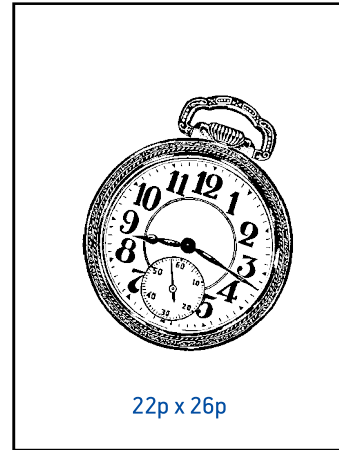

22p x 26p

**STOCK METAL
INLAY TIME**

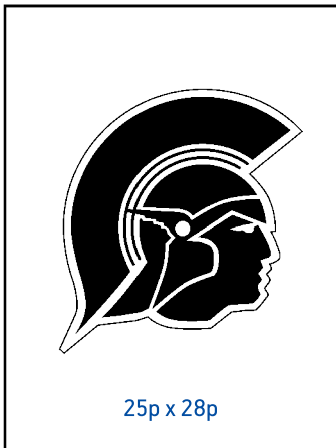

25p x 28p

**STOCK METAL
INLAY TROJAN**



24p x 37p

**STOCK METAL
INLAY KNIGHT ON HORSE**

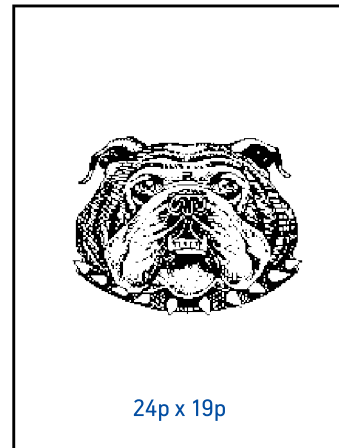

24p x 19p

**STOCK METAL
INLAY BULLDOG**



29p x 35p

**STOCK METAL
INLAY SHIP**

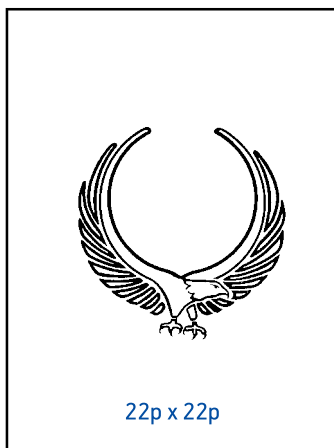

22p x 22p

**STOCK METAL
INLAY EAGLE IN FLIGHT**

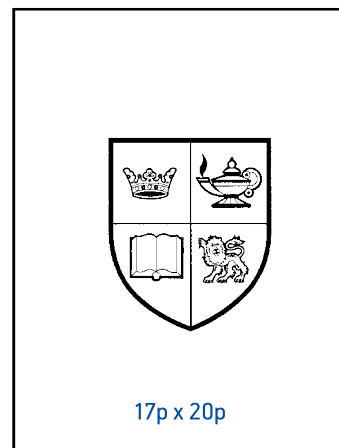

17p x 20p

**STOCK METAL
INLAY CREST**

STOCK METAL INLAY DESIGNS

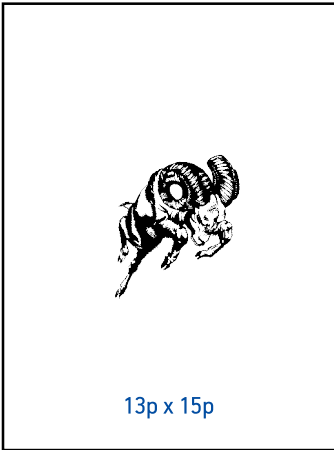

**STOCK METAL
INLAY RAM**



**STOCK METAL
INLAY VIKING**

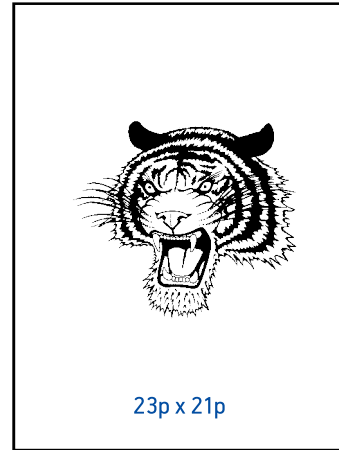

**STOCK METAL
INLAY WILD TIGER**

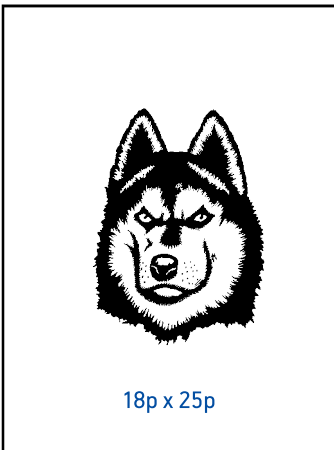

**STOCK METAL
INLAY HUSKY**

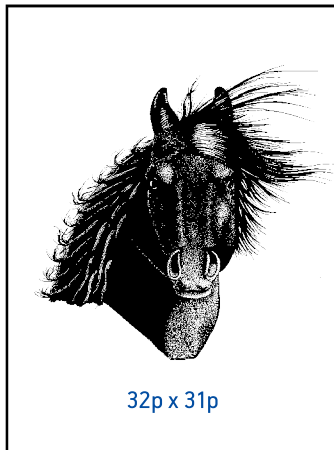

**STOCK METAL
INLAY MUSTANG**

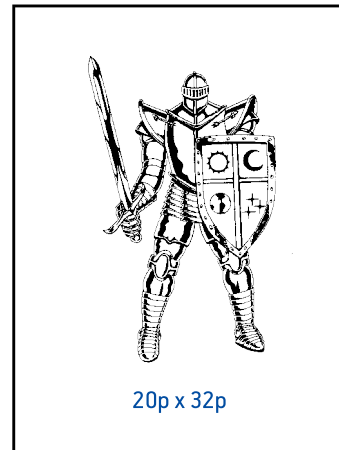

**STOCK METAL
INLAY KNIGHT**

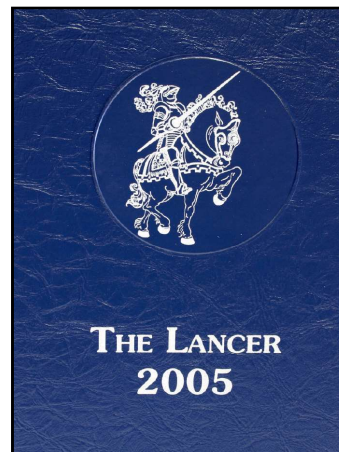
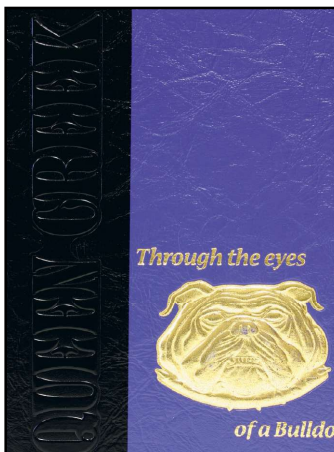
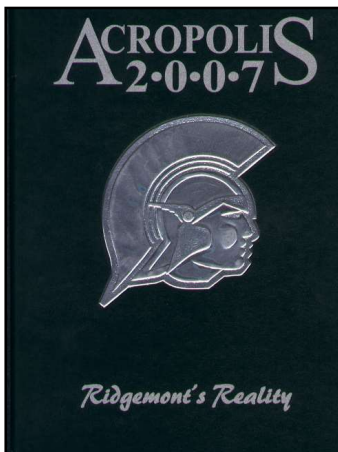



NOTES & IDEAS



Handwriting practice area consisting of 21 horizontal lines. The first line is a thick blue double line, and the subsequent 20 lines are thin grey single lines.





One Memory Lane • Altona, Manitoba • R0G 0B0
P 1.888.324.9725 • F 1.877.405.1190 • ybmarketing@friesens.com

YEARBOOKS.FRIESENS.COM